

# Time-domain measurement of fluorescence lifetime variation with pH.

Alan G. Ryder<sup>\*a</sup>, Sarah Power<sup>a</sup>, Thomas J. Glynn<sup>a</sup>, and John J. Morrison<sup>b</sup>.

<sup>a</sup> Department of Physics, NUI- Galway, Ireland.

<sup>b</sup> Department of Obstetrics and Gynecology, NUI- Galway, Ireland.

## ABSTRACT

Advances in the design and miniaturization of the lasers and electronics required for Time Correlated Single Photon Counting (TCSPC) measurement of fluorescence lifetime have simplified the use of the time domain method. We have assembled a compact portable system that is capable of measuring lifetimes down to ~200 ps (with deconvolution) and that can operate at a range of excitation and emission wavelengths. The excitation sources are pulsed LEDs and laser diodes with a maximum pulse rate of 40 MHz and are easily interchanged. Furthermore, the development of violet and blue GaN LEDs and laser diodes is expanding the range of fluorophores available for fluorescence lifetime measurement of ion concentrations.

pH sensitive fluorophores have a wide range of biological and clinical applications. The use of fluorescence lifetime rather than intensity to measure pH has a number of advantages including the reduction of effects due to photobleaching, scattering, and intensity variations in the excitation source. Using our compact TCSPC instrumentation we have measured the dependence of fluorescence lifetimes on pH for a range of dyes in phosphate buffer over the physiologically important range of 6.0 to 8.0. Most dyes exhibit only a small variation in lifetime (<1.0 ns) over the 6.0 to 8.0 pH range; however, acridine exhibits a large variation in lifetime and hence shows promise as a pH indicator.

Keywords: Fluorescence, lifetime, time correlated single photon counting, laser diode, light emitting diode, pH.

## 1. INTRODUCTION:

Fluorescence lifetimes in the nanosecond range have typically been measured by either of two methods, Time Correlated Single Photon Counting (TCSPC)<sup>1</sup> or phase modulation.<sup>2</sup> Phase modulation methods have enjoyed widespread success in the past for the relative simplicity of the instrumental setup. TCSPC, on the other hand, has been seen as the more complex method, relying on expensive detectors and complex electronics. Furthermore, the TCSPC method was generally implemented with either flash lamp sources (100 KHz pulse rates) which were very slow in data collection or with complex fast-pulsed lasers which were restricted to several distinct wavelength regions. In effect, TCSPC was a complex method confined (when using lasers) to large well-equipped laser laboratories and relied on a large degree of expertise. Recently, however, the emergence of new LED and laser diode technologies along with miniaturized electronics has enabled Time Correlated Single Photon Counting (TCSPC) methods to gain more widespread use.<sup>3, 4</sup> Such miniaturization of the electronics for TCSPC onto a single PC board with software control has at a stroke made the method much more accessible.<sup>5</sup> Semiconductor LEDs and lasers as fluorescence excitation sources have improved dramatically in the past decade and will revolutionize fluorescence lifetime measurement systems.<sup>6, 7, 8</sup> LED devices can now offer excitation wavelengths of between 380 nm and 600 nm with pulse rates in excess of 1 MHz and pulse widths of ~1 ns, which is ideal for mainstream biological

---

\* Corresponding author: [alan.ryder@nuigalway.ie](mailto:alan.ryder@nuigalway.ie); phone: 353-91-750469; fax: 353-91-750584; <http://www.physics.nuigalway.ie/People/ARyder/index.html> ;  
Department of Physics, National University of Ireland-Galway, Galway, Ireland.

fluorescence lifetime studies. A further development has been the emergence of commercial violet GaN laser diodes in the past two years. These lasers are compact, capable of pulse widths less than 100 ps, and are easily incorporated into fluorescence lifetime systems.

The use of fluorescence lifetimes as a sensor method has attracted widespread interest in the past decade.<sup>9,10,11</sup> Analytes such as halides,<sup>12</sup> oxygen,<sup>13</sup> and carbon dioxide,<sup>14</sup> have been monitored using fluorescence lifetimes. Fluorescence lifetime based techniques have several advantages over more traditional fluorescence intensity methods which are susceptible to changes in excitation light intensity, to photobleaching, variation in light scattering and absorption of the sample.

## 2. EXPERIMENTAL:

### 2.1 Apparatus and Procedure.

Fluorescence lifetimes were recorded using the Time Correlated Single Photon Counting (TCSPC) technique with a system that was assembled in-house using modular components (Figure 1).

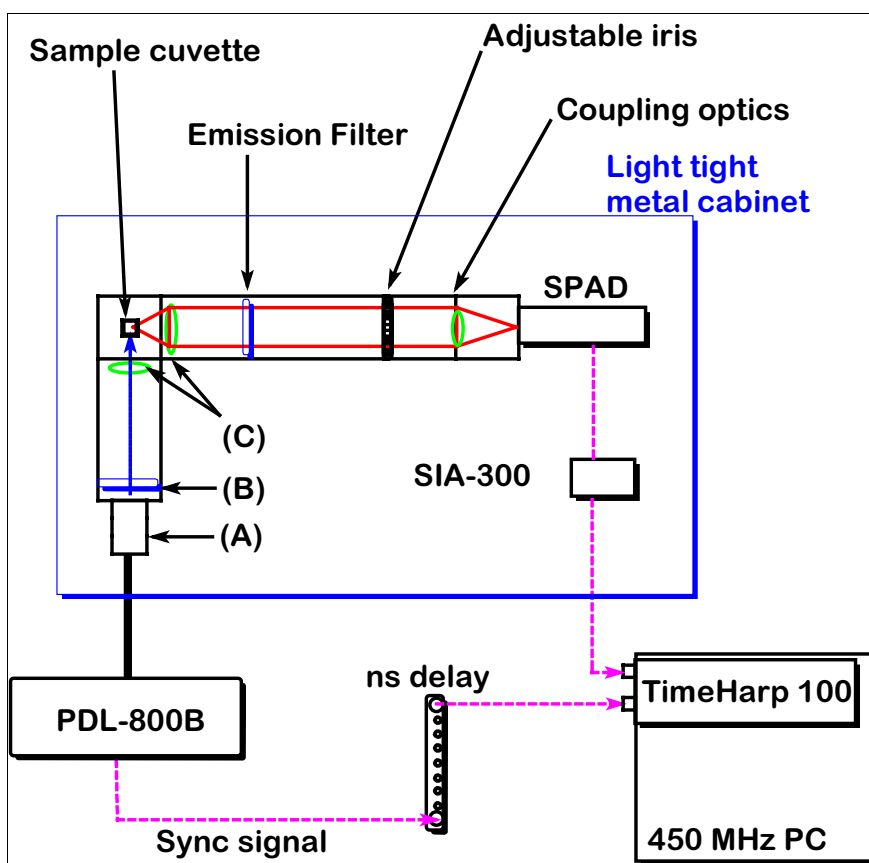

Figure 1: Schematic of fluorescence lifetime measurement apparatus:  
(A) Removable LED/ laser diode head, (B) Short pass filter, (C) Focusing optics.

The excitation sources were pulsed LEDs with center wavelengths of 380 and 460 nm or a pulsed 410 nm GaN laser diode, powered by a PicoQuant PDL-800B laser/LED driver. The emission of the LEDs was filtered using short pass filters to remove spurious longer wavelength emissions. The LEDs were operated at a variety of frequencies from 2.5 to 20 MHz for this study (maximum pulse rate = 40 MHz). A variable nanosecond delay unit was incorporated into the SYNC output from the laser driver. The fluorescence emission wavelength was selected with interference filters and detected using a Perkin Elmer SPCM-AQR-14 Single Photon Counting Module. The output TTL pulses from the SPAD were inverted and attenuated to NIM format using a SIA 300 inverter module before being fed into a TimeHarp 100 TCSPC module (both from PicoQuant). The card with a minimum channel resolution of 35 picoseconds was integrated into a standard PC, and the start/stop signals were inputted via RG58 SMA terminated cables. Light intensity at the detector was varied using an adjustable iris in front of the detector and by the use of ND filters. With the exception of the delay unit, laser driver and PC the complete unit was fitted into a light tight, 21x40x50 cm mild steel cabinet.

The Instrument Response Function (IRF) was obtained from a non-fluorescing suspension of alumina in water held in a 1 cm pathlength quartz cell and was assumed to be wavelength independent. Decay data were acquired until between  $5 \times 10^3$  and  $3 \times 10^4$  counts had been registered in the channel of maximum intensity. The determining factor as to the count maximum was the count rate, which was always <1% of the pulse rate. Count rates of  $10^4$  and  $10^5$  per second were routinely obtained from strongly fluorescing dyes yielding faster accumulating times by an order of magnitude or more when compared to flash-lamp systems. Lifetimes were obtained by deconvolution of the decay curves using the FluoFit software program (PicoQuant GmbH, Germany). All lifetimes were fit to a  $\chi^2$  value of less than 1.2 and with a residuals trace that was fully symmetrical about the zero axis.

## 2.2 Materials:

Fifteen dyes in 0.1 M aqueous phosphate buffer were analyzed over a pH range from 5.8-8.0. The fluorophore concentration was maintained below  $1 \times 10^{-3}$  M to rule out concentration effects. An absorption profile of each dye was recorded on a Shimadzu UV-1601 UV-visible spectrophotometer, and the excitation sources were chosen accordingly. Steady state fluorescence spectra of each dye were recorded on a Perkin Elmer LS 50B luminescence spectrometer to determine the correct emission filter for fluorescence lifetime measurements. All the dyes were surveyed in oxygenated and deoxygenated (nitrogen gas exchange) solutions at room temperature in 1 cm pathlength quartz cuvettes.

## 3. RESULTS & DISCUSSION:

The TCSPC system as developed was found to be user-friendly and required very little training for postgraduate student use. Once an operator had a sufficient grasp of TCSPC theory and methods, it required only one or two days to develop proficiency sufficient for routine measurements to be made. Apart from care needed to reduce reflection anomalies, the only other major concern is the requirement to ensure adequate filtering of the excitation sources to remove spurious long wavelength emissions and to remove the long wavelength 'tail' produced by LED emission. Figure 2(A) shows typical multi-exponential fits for two acridine decay curves at different pH values. The IRF curve shown (FWHM ~ 1.5 ns or less) is typical of the IRFs obtained with our instrumentation when LEDs were used as excitation sources.

|                                    | $\lambda_{\text{ex}}$<br>(nm) | $\lambda_{\text{em}}$<br>(nm) | $\tau(\text{O}_2)$<br>(ns) | $\tau(\text{O}_2)$<br>(ns) | $\tau$<br>(ns) | $\tau$<br>(ns) |
|------------------------------------|-------------------------------|-------------------------------|----------------------------|----------------------------|----------------|----------------|
| <b>pH</b>                          |                               |                               | <b>low</b>                 | <b>high</b>                | <b>low</b>     | <b>high</b>    |
| Fluorescein                        | 460                           | 550                           | 3.6                        | 4.2                        | 3.6            | 4.2            |
| Fluorescein Na salt                | 460                           | 550                           | 3.6                        | 4.2                        | 3.6            | 4.3            |
| Fluorescein diacetate              | 460                           | 550                           | 3.5                        | 4.0                        | 3.5            | 4.0            |
| Fluoresceinamine Isomer 1          | 460                           | 550                           | 3.3                        | 3.9                        | 3.3            | 3.9            |
| Fluoresceinamine Isomer 2          | 460                           | 550                           | 3.0                        | 3.9                        | 3.0            | 4.0            |
| FITC                               | 460                           | 550                           | 3.4                        | 4.1                        | 3.4            | 4.1            |
| 6-Carboxyfluorescein               | 460                           | 550                           | 3.5                        | 4.0                        | 3.5            | 4.0            |
| BCECF                              | 460                           | 550                           | 3.0                        | 3.8                        | 3.0            | 3.8            |
| SNAFL calcein                      | 460                           | 550                           | 3.4                        | 2.7                        | 3.4            | 2.7            |
| HPTS                               | 410                           | 500                           | 5.4                        | 5.4                        | 5.4            | 5.4            |
| 10-(3-Sulfonyl) acridinium betaine | 380                           | 500                           | 31.2                       | 30.6                       | 31.2           | 30.7           |
| Acridine Orange                    | 460                           | 550                           | 1.9                        | 2.0                        | 1.9            | 2.0            |
| Rhodamine B                        | 410                           | 600                           | 1.8                        | 1.7                        | 1.8            | 1.8            |
| Acridine                           | 380                           | 450                           | 26.3                       | 13.7                       | 26.3           | 14.0           |
| Acridine                           | 380                           | 500                           | 31.1                       | 22.1                       | 31.2           | 22.4           |

Table 1 Fluorescence lifetimes of a range of dyes at pH  $5.8 \pm 0.2$  (low) and  $7.9 \pm 0.2$  (high) in phosphate buffered solutions. The first two lifetime values are for oxygenated solutions while the last two represent the deoxygenated solutions. All decay curves were either single or bi-exponential fits. Lifetime measurements are accurate to better than  $\pm 0.1$  ns, as calculated by support plane analysis<sup>16</sup>.

With the exception of acridine, the majority of fluorophores show little lifetime variation over the pH range surveyed (table 1). Typical variation was less than one nanosecond while the lifetimes of acridine orange, Rhodamine B, and HPTS were found to be independent of pH over the 6.0 to 8.0 range. The results acquired for HPTS agree with those of other investigators.<sup>15</sup> The majority of dyes surveyed are therefore unsuitable as fluorescence lifetime based pH sensors because of the small variation in lifetime. The presence of oxygen was not found to be a significant factor affecting the fluorescence lifetime of these dyes, except for the base form of acridine where there is a 0.3 ns increase in lifetime with deoxygenation.

Over this 6.0 to 8.0 pH range, acridine in solution exhibits interplay between two different chemical species that have a large difference in lifetime. The neutral acridine exhibits a lifetime of  $\sim 10$  ns, while the protonated form has a considerably longer lifetime of 31 ns. This is well illustrated in Figure 2(A) where it is clear that two decays are present at each pH value, with both decay curves fitting to bi-exponential terms.

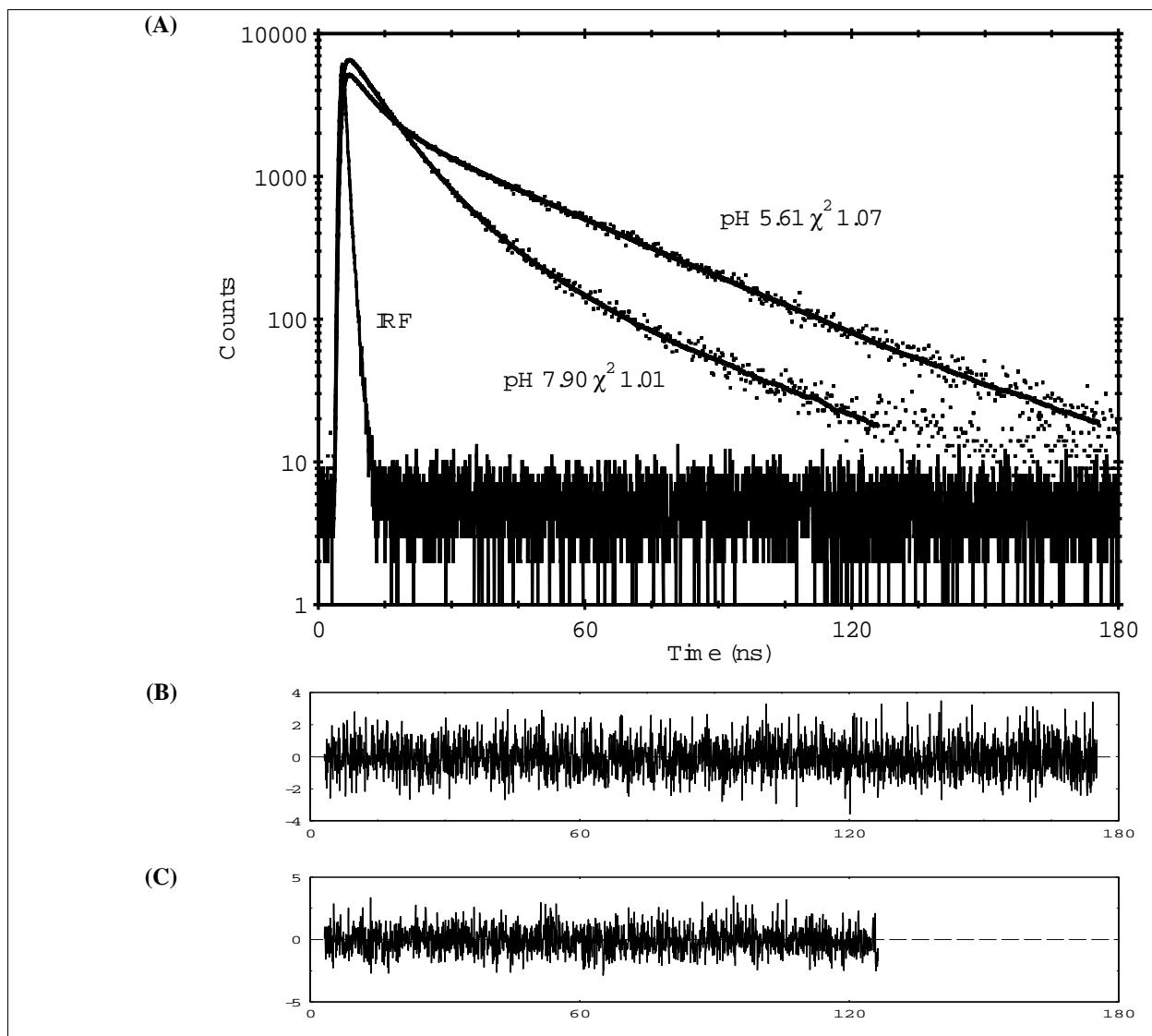

Figure 2: (A) Time domain intensity decay of acridine solutions at pH 5.61 & pH 7.90 (dotted lines), multi-exponential fit (solid lines), and the instrument response function. (B) Residuals for fit at pH 5.61, (C) Residuals for fit at pH 7.90. Data collected with 380 nm LED excitation at 2.5 MHz pulse rate, with the emission measured at 450 nm and a channel resolution of 70 ps.

The lifetime plots in Figure 3 show the change in average lifetime of acridine as a function of pH. At an emission wavelength of 450 nm the average lifetime is calculated from a two exponential decay fit which is a combination of fluorescence from both the neutral and protonated species. At an emission wavelength of 500 nm, there is a much greater contribution from the protonated rather than the neutral form of the dye, so the lifetime at any given pH is longer than that

measured at an emission wavelength of 450 nm. Measured at 500 nm, lifetimes in the pH range 5.8-6.4 fit to a single exponential therefore demonstrating negligible contributions from the neutral molecule. At pH values greater than 6.4 the fluorescence emission from the neutral species becomes a larger factor and so a bi-exponential fit is required. Both lifetime vs pH plots for acridine fit to 2<sup>nd</sup> order polynomial equations over this 6.0 to 8.0 range (Figure 3) which provides a simple and accurate method of pH measurement from the average fluorescence lifetime.

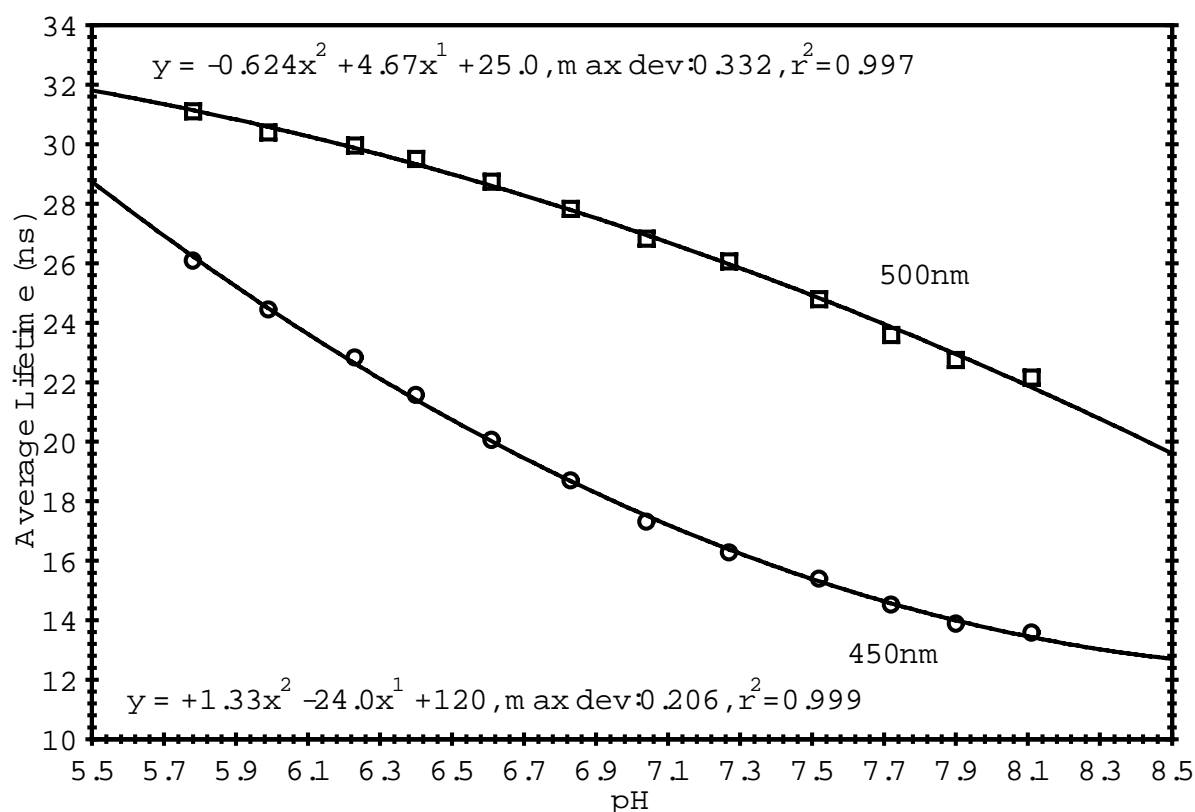

Figure 3: Plots of average fluorescence lifetime versus pH for acridine in phosphate buffer with 380 nm excitation and at two different emission wavelengths (450 & 500 nm). The two emission curves show different behaviour due to the two species in solution.

#### 4. CONCLUSIONS:

The compact nature and relative ease of use of the TCSPC system which we have built opens the way for this method to be employed by non-physicists for routine analysis. Although a thorough grounding in the principles and theory of TCSPC is necessary, very little knowledge of electronics and optics is required. The ease with which the excitation sources can be changed also demonstrates its versatility towards biological applications where a range of dyes may need analysis at the same

time. Although fast-pulsed lasers do exist, they tend to be very large, complex, and generally only provide a single wavelength, or range of wavelengths. By the use of pulsed LEDs and laser diodes, a range of dyes can be excited at visible and near-IR wavelengths between 380 nm and 750 nm with no change in the optical pathway and rapid exchange of sources.

The fluorophores which we have examined showed varying degrees of lifetime change with pH variation. Most dyes had a lifetime change of less than one nanosecond over the crucial physiological range of 6.0 to 8.0 pH units and we therefore discount them as potential lifetime based pH sensors. Acridine was found to have the largest lifetime variation of 12.5 ns over the range 5.8 to 8.0 pH units and because it can be excited with a 380 nm LED we consider it an excellent candidate as a pH indicator for a wide variety of biological applications.

## 5. ACKNOWLEDGEMENTS:

The work was funded by grants from the Irish Higher Education Authority, under its Programme for Research in Third Level Institutions, and by a Millennium Research Fund grant from NUI-Galway.

## 6. REFERENCES:

- 
- 1 D.V. O'Connor and D. Phillips, *Time-correlated Single Photon Counting*, Academic Press, London, 1984.
  - 2 J.R. Lakowicz and I. Gryczynski, *Frequency-Domain Fluorescence Spectroscopy*. In: *Topics in fluorescence spectroscopy: Volume 1 Techniques*, J. R. Lakowicz editor, pp. 293-335, Plenum Press, New York, 1991.
  - 3 Y.L. Zhang, S.A. Soper, L.R. Middendorf, J.A. Wurm, R. Erdmann, M. Wahl, "Simple near-infrared time-correlated single photon counting instrument with a pulsed diode laser and avalanche photodiode for time-resolved measurements in scanning applications," *Appl. Spectrosc.* **53**, pp. 497-504, 1999.
  - 4 W. Becker, H. Hickl, C. Zander, K.H. Drexhage, M. Sauer, S. Siebert, J. Wolfrum, "Time-resolved detection and identification of single analyte molecules in microcapillaries by time-correlated single-photon counting (TCSPC)," *Rev. Sci. Instrum.* **70**, pp. 1835-1841, 1999.
  - 5 Three companies which supply TCSPC electronics on a single board are: PicoQuant GmbH, Berlin Germany, Becker & Hickl, Berlin, Germany, and Edinburgh Instruments, UK.
  - 6 T. Araki and H. Misawa, "Light emitting diode-based nanosecond ultraviolet light source for fluorescence lifetime measurements," *Rev. Sci. Instrum.* **66**, pp. 5469 1995.
  - 7 H. Szmecinski and Q. Chang, "Micro- and sub-nanosecond lifetime measurements using a UV light-emitting diode," *Appl. Spectrosc.* **54**, pp. 106-109, 2000.
  - 8 J. Sipior, G.M. Carter, J.R. Lakowicz, and G. Rao, "Blue light-emitting diode demonstrated as an ultraviolet excitation source for nanosecond phase-modulation fluorescence lifetime measurements," *Rev. Sci. Instrum.* **68**, pp. 2666- 1997.
  - 9 H. Szmecinski and J. R. Lakowicz, *Lifetime-Based Sensing*. In: *Topics in fluorescence spectroscopy: volume 4 Probe design and chemical sensing*, J. R. Lakowicz editor, p.295, Plenum Press, New York, 1994.
  - 10 S. Draxler, M.E. Lippitsch. "Optical pH sensors using fluorescence decay time," *Sens. Actuators B*, **11**, pp. 421-424, 1993.

- 
- 11 J.R. Lakowicz, H. Szmecinski. "Fluorescence lifetime-based sensing of pH, Ca<sup>2+</sup>, K<sup>+</sup> and glucose," *Sens. Actuators B*, **11**, pp.133-143, 1993.
  - 12 H. Szmecinski, J.R. Lakowicz. "Potassium and sodium measurements at clinical concentrations using phase-modulation fluorometry," *Sens. Actuators B*, **60**, pp. 8-18, 1999.
  - 13 G.A. Holst, T. Köster, E. Voges & D.W. Lübbers. "FLOX – an oxygen-flux-measuring system using a phase-modulation method to evaluate the oxygen-dependent fluorescence lifetime," *Sens. Actuators B*, **29**, pp. 231-239, 1995.
  - 14 J. Sipior, S. Bambot, M. Romauld, G.M. Carter, J.R. Lakowicz and G. Rao, "A lifetime-based optical CO<sub>2</sub> gas sensor with blue or red excitation and stokes or anti-stokes detection," *Anal. Biochem.*, **227**, pp. 309-318, 1995.
  - 15 O. S. Wolfbeis, E. Furlinger, H. Kroneis, H. Marsoner, "Fluorimetric Analysis 1. A study on fluorescent indicators for measuring near neutral ("physiological") pH-values," *Fresenius Z Anal Chem*, **314**, pp.119-124, 1983.
  - 16 J. R. Lakowicz, *Principles of Fluorescence Spectroscopy*, pp.122-125, Kluwer Academic/Plenum Publishers, New York, 1999.