

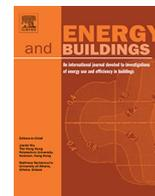

## **A novel reduced order model technology framework to support the estimation of the energy savings in building retrofits**

Title	A novel reduced order model technology framework to support the estimation of the energy savings in building retrofits
Author(s)	Piccinini, Alessandro;Hajdukiewicz, Magdalena;Keane, Marcus M.
Publication Date	2021-03-13
Publisher	Elsevier
Repository DOI	<a href="https://doi.org/10.1016/j.enbuild.2021.110896">10.1016/j.enbuild.2021.110896</a>



# A novel reduced order model technology framework to support the estimation of the energy savings in building retrofits



Alessandro Piccinini<sup>a,b,c,\*</sup>, Magdalena Hajdukiewicz<sup>a,b,c</sup>, Marcus M. Keane<sup>a,b,c</sup>

<sup>a</sup>School of Engineering, College of Science and Engineering, National University of Ireland Galway, Ireland

<sup>b</sup>Informatics Research Unit for Sustainable Engineering (IRUSE) Galway, Ireland

<sup>c</sup>Ryan Institute, National University of Ireland Galway, Ireland

## ARTICLE INFO

### Article history:

Received 20 December 2020

Revised 17 February 2021

Accepted 8 March 2021

Available online 13 March 2021

### Keywords:

Reduced order model

International performance measurement and verification protocol

Energy savings

Building retrofiting

Energy performance contracting

## ABSTRACT

Energy Performance Contracting (EPC), as a tool to enhance energy efficiency of buildings, can accelerate investment in cost-effective energy conservation measures (ECMs) for existing buildings. However, there are many risks and barriers that can slow down the uptake of EPC, such as the complexity of the process or uncertainty of building performance post-retrofit. The International Performance Measurement and Verification Protocol (IPMVP<sup>®</sup>), which was originally developed to help increase investment in energy and water efficiency, demand management and renewable energy projects, has the potential to reduce some of the EPC barriers. However, due to limited and uncertain information about existing buildings, the application of this Measurement and Verification (M&V) protocol in retrofitting projects is often complex and requires novel use of building simulation tools.

In order to address the challenges of utilising M&V IPMVP<sup>®</sup> in building retrofitting projects, and to enhance the uptake of EPC, the research presented here developed a novel Reduced Order Model (ROM) technology framework that can be used for (i) systematic quantification of energy savings (avoided energy consumption) achieved through ECMs, and (ii) direct estimation of energy savings through the investigation of different envelope retrofit scenarios. The framework was demonstrated on pilot buildings in Sant Cugat, Spain.

© 2021 The Authors. Published by Elsevier B.V. This is an open access article under the CC BY license (<http://creativecommons.org/licenses/by/4.0/>).

## 1. Introduction

### 1.1. Overview

In the last decade, the European Union (EU) has developed policies aimed at accelerating the cost-effective retrofitting of existing buildings, with the vision of a decarbonised building stock by 2050 [14].

One of the potential measures to target this objective and to enhance the energy efficiency of buildings is Energy Performance Contracting (EPC) [2]. Defined by the Energy Efficiency Directive 2012/27/EU [13], EPC is a form of 'creative financing' for capital improvement which allows funding energy upgrades from cost reductions [8].

However, there are different risks and barriers opposing the uptake of EPC, such as process complexity, lack of information, uncertainty about post-retrofit energy performance, access to

finance, lack of trust in Energy Service Companies (ESCO, which develop, design, build and arrange out EPC), lack of skilled professionals, fragmentation of value chain and unclear financial mechanisms [29].

### 1.2. Measurement and Verification

Measurement and Verification (M&V) protocol can reduce some uncertainties of EPC. M&V is a procedure of measuring and analysing data from operating buildings, and reporting energy savings within a system or a whole facility. M&V underpins and enhances a standards-based approach for the implementation of energy conservation measures (ECMs). Guidelines regarding the M&V protocol are provided by the International Performance Measurement and Verification Protocol (IPMVP<sup>®</sup>) [9]. This protocol defines a standard approach to estimate the potential and actual energy savings and can be used to quantify the payments to all stakeholders throughout the EPC process. One of the main recommendations of the IPMVP<sup>®</sup> guidelines is that the M&V costs do not exceed 10% of the average annual savings achieved through its application.

\* Corresponding author at: Civil Engineering, Alice Perry Engineering Building, National University of Ireland Galway, University Road, Galway H91 HX31, Ireland.  
E-mail address: [Alessandro.piccinini@nuigalway.ie](mailto:Alessandro.piccinini@nuigalway.ie) (A. Piccinini).

In measuring and verifying the results of energy efficiency projects, the IPMVP<sup>®</sup> provides four options referenced from A–D [11]. The work presented here relates directly to option D, which consists of a development of a calibrated computer simulation model that supports detailed analysis of various ECMs. According to IPMVP<sup>®</sup>, option D should be undertaken i) for projects that generate enough savings to justify its use; ii) when creating a baseline is not simple with other options (i.e. A–C); and iii) when the ECMs responsible for the savings cannot be easily measured. Option D also provides an opportunity to evaluate savings of one or multiple ECMs and, thus, to test the best retrofit scenario for a particular building.

### 1.3. White and black box models

Many software tools are suggested in the IPMVP<sup>®</sup> to analyse energy consumption and determine building control and operation opportunities, including eQUEST [12], EnergyPlus [10], and IES-VE [23]. These tools are classified as a Whole Building Energy Simulation Modelling (WBESM) or white box models. WBESM can provide the most comprehensive prediction of building energy performance, with a vast range of detailed outputs from energy consumption to indoor comfort. These models are also suitable for retrofit analysis as detailed physics-based equations can be used to model and implement building components, systems and subsystems prior to any retrofit. However, a high computational time [30], complexity and cost of model implementation, and the uncertainty of model parameters [15] pose barriers for the application of WBESM in IPMVP<sup>®</sup> and, in general, for energy performance prediction of existing buildings in the deep-retrofit processes [21].

Black box models are the alternative to white box modelling and consist of purely empirical approach. The black box approach is data driven and does not require knowledge about the system. It includes building monitoring and implementing simple mathematical or statistical models (e.g. ANN, ARX, etc.) to predict energy consumption. The accuracy of black box models is achieved through a large amount of high-quality measured data. Although black box models are based on measured data, the model variables are abstract, do not have any physical meaning [39] and the weight of input variables depends on their impact on model output. Black box models are unique for each building. Thus, the approach has limited use in new constructions and major building retrofits, and it is difficult to physically interpret model results. Therefore, the ability of black box models to predict building behaviour post-retrofit or altering control strategies cannot be demonstrated [4].

### 1.4. Grey box models

Grey box models are a synthesis of white and black box models. They consist of coupling of the physical meaning and model structure (parameter values from building data or existing literature) of the building from the white box paradigm, and the statistical approach and parameter estimation from the black box approach. In general, the grey box model structure simplifies the physical description of the building using thermal network analogies and treating the system complexity as an electrical circuit problem. This is done through the use of resistances and capacitances (RC), where thermal mass of the building is divided into a discrete number of capacitances, based on the model type [38], and resistances (e.g. walls). The number of capacitances, not including the air mass, give the order of the model, as extensively explained in M. Lauster et al. [28].

Grey box models have both, the physical meaning and high grade of generality. RC network allows for model parameters to be related to existing building components and this enables the

use of the same model structure for different buildings. In recent years, grey box models have become increasingly popular in evaluating the environmental and energy performance of buildings. One of the most compressive comparisons of grey box models' accuracy was provided by Bacher and Madsen [3], with similar studies performed by Fux et al. [17], Reynders et al. [38], and Berthou et al. [4]. However, there are numerous challenges with the use of grey box approach to simulate existing buildings.

Firstly, there is uncertainty associated with errors and approximations in measured data and parameter estimation, material degradation, and missing building specific information. Secondly, the historical data, used for the estimation of building parameters, can often be analysed without the correct/complete information about the existing building. The physical meaning of each model parameter is particularly important when analysing/developing different retrofit packages.

In order to address these challenges, M. Lauster et al. [28] proposed to use the Modelica language (Modelica is a non-proprietary, object-oriented, equation based language [31]) to compare the first order grey box model described in EN ISO 13790 [27] to the second order grey box model described in Guideline VDI 6007 [40]. Based on that, an open source Modelica Library AixLib [32] was created, with the TEASER tool [37] to generate and simulate Modelica models at both building and district level. The TEASER tool also allowed the application of retrofit scenarios. However, it was unclear how the TEASER tool could be incorporated into a formal EPC business process model and in the application of the M&V protocol since the software does not allow for the creation of baseline period energy consumption and a workflow for the calibration of energy models, based on real building energy consumption, is missing.

Due to this concern, Giretti et al. [19] proposed an extension of the third order building model proposed by Bacher and Madsen [3], which was developed and used as the baseline energy model for an EPC tendering phase.

The research presented here expands the Giretti et al. [19] model in order to meet the IPMVP<sup>®</sup> objectives and its calibration limits. This paper presents a ROM to be used in the IPMVP<sup>®</sup> and a newly developed parameter calculation tool (ROMPar) that deals with correct estimation of model inputs. The updated ROM provided a more accurate building representation (both in terms of building physics, heating and cooling systems) and, thus, more accurate model predictions.

This novel ROM technology framework is used for (i) systematic quantification of energy savings (avoided energy consumption) achieved through the ECMs and (ii) direct estimation of energy savings through the investigation of different envelope retrofit scenarios. The framework is demonstrated on educational buildings in Sant Cugat, Spain which underwent the installation of ECMs, such as energy efficient lighting, PV panels and envelope retrofits.

## 2. Methodology

The proposed ROM technology framework (Fig. 1) consisted of three phases:

1. ROMPar calculation tool for ROM parameters' estimation, which receives building specific data as input.
2. Development, simulation and calibration of the Modelica ROM.
3. ROM utilisation.

### 2.1. Phase 1 – ROMPar

Phase 1 of the framework consisted of the development and utilisation of the ROMPar tool, which was created to estimate 48 parameters needed for the ROM. This Excel-based tool was not

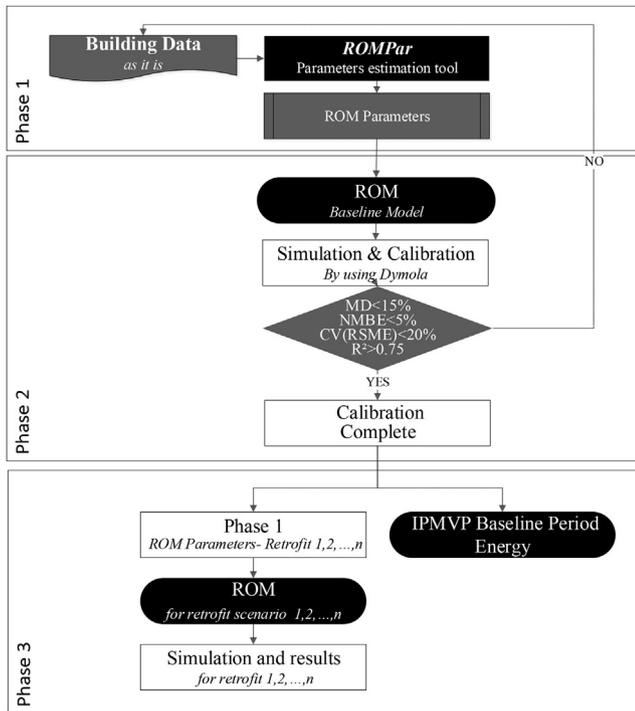

Fig. 1. ROM technology framework.

developed to reduce the effort of on-site measurements, but to calculate the majority of required parameters using formulae and methods defined in relevant standards.

For instance, thermal resistances of both, the internal and external walls, were calculated as specified in ISO 6946 [26], internal and external windows heat losses were calculated using U-values of the windows, and by using a simplified version of the ISO 10077 [24]. Thermal resistance values of the ground floor were calculated with a simplified version of the ISO 13370 [25]. Thus, the G-total value was calculated from standard configuration using the BS EN 13363-1 [6]. The thermal resistances and capacitances were calculated using standard values, material properties and construction composition. For the profiles' generation, a graphical interface was included in ROMPar and the numerical output needed by the model was given.

A detailed description of ROMPar can be found in Piccinini [36].

## 2.2. Phase 2 – The Modelica ROM utilisation and calibration

The phase 2 consisted of the development, simulation and calibration of the Modelica ROM. The structure of the developed ROM was an extension of models proposed Bacher and Madsen [3] and Giretti [19].

The ROM was created utilising the ability of Modelica [16] language to be integrated into the Dymola Environment [7]. Dymola is a commercial modelling and simulation environment based on the open source Modelica modelling language. The selection of this language was due to three main reasons. Firstly, it allows to model complex dynamic energy systems supported by an object-oriented modelling and simulation. Secondly, the language recognises linear, non-linear and hybrid equations; and finally, many open source and commercial simulation environments support Modelica providing several numerical solvers, algorithms and libraries such as the IBPSA Project 1 Library [22], which was implemented in the model.

The ROM simulations run using the Radau Ila Algorithm [20] of Dymola. After the first simulation the uncertain parameters were changed to calibrate the model and verify it with energy consumption data. The ROM's structure and its low number of parameters (compared to the white box approach) helped reducing the degree of freedom of the calibration phase, thus reducing the possibility of over-fitting issues. For this reason, a knowledge-based calibration procedure, based on the method described by Giretti [19], was utilized to select the parameters more affected by uncertainty and correct their values in the calibration phase.

The ROM was considered calibrated when complied with the statistical limits suggested by the IPMVP® (i.e. Normalised Mean Biased Error (NMBE), Coefficient of Variation of Root Mean Square Error (CV(RMSE)), Coefficient of Determination ( $R^2$ ) and monthly deviation). In this case the model could be used in the third phase of the process as a baseline for the M&V or for the application of different retrofit scenarios. Otherwise, if the model did not comply with the statistical limits, the building data would have to be manually adjusted and the simulation and calibration process repeated.

Fig. 2a shows the ROM as a RC network. The RC network divided the building's mass into three capacitances representing all internal partitions ( $C_m$ ), the external opaque envelope ( $C_{wall}$ ) and all floor slabs in contact with the ground ( $C_{gf}$ ). The heat transfer between the nodes (e.g.  $T_{in}$ ) was divided into radiative and convective heat transfer. The high number of thermal resistances was due to the division of each resistance element into an internal surface resistance (e.g.  $R_{wall_{is}}$ ), external surface resistance (e.g.  $R_{wall_{es}}$ ) and a thermal resistance (e.g.  $R_{wall}$ ). The thermal resistance was divided by two in order to apply the thermal capacitance at the middle point.

$L_{rate}$  and  $NV_{rate}$  were two components used to simulate respectively the air infiltration and the natural ventilation.  $C_{AIR}$  was the room capacitance represented in Modelica with the MixingVolume element.  $\%Q_{SI}$  and  $Q_{SC}$  were the radiative and convective heat gain generated by the solar.  $\%Q_{GI}$  and  $Q_{GC}$  were the radiative and convective part of the heat gain due to the 'Internal gains' component. Finally,  $Q_{HC}$  was the system heat gain which was generated by the component 'Heating and cooling system'.

Fig. 2b shows the RC network (Fig. 2a) developed in Modelica, which consisted of four main components:

- Internal gains (generating  $\%Q_{GI}$  and  $Q_{GC}$ ),
- Heating and cooling system (generating  $Q_{HC}$ ),
- Building (containing the RC network and generating the  $L_{rate}$ ,  $NV_{rate}$ ,  $\%Q_{SI}$  and  $Q_{SC}$ )
- Weather data.

As demonstrated in [34], since the model considered the main physical dependencies among each variable, the calibration phase was far less complicated than the white box approach. For this reason, dedicated parameters were inserted into the ROM in order to increase the speed and accuracy of the calibration process.

The calibration was done using an iterative procedure that consisted of changing these parameters within their possible ranges. Simulation run for every parameter selection, and the resulting simulated baseline model energy consumption was compared with measured energy consumption data using the following statistical indices and their limits [9]:

- Normalised Mean Biased Error →  $NMBE < 5\%$

$$NMBE = \frac{1}{\bar{Y}} \sqrt{\sum_{i=1}^n \left( \frac{\hat{Y}_i - Y_i}{n - 1 * 100(\%)} \right)^2} \quad (1)$$

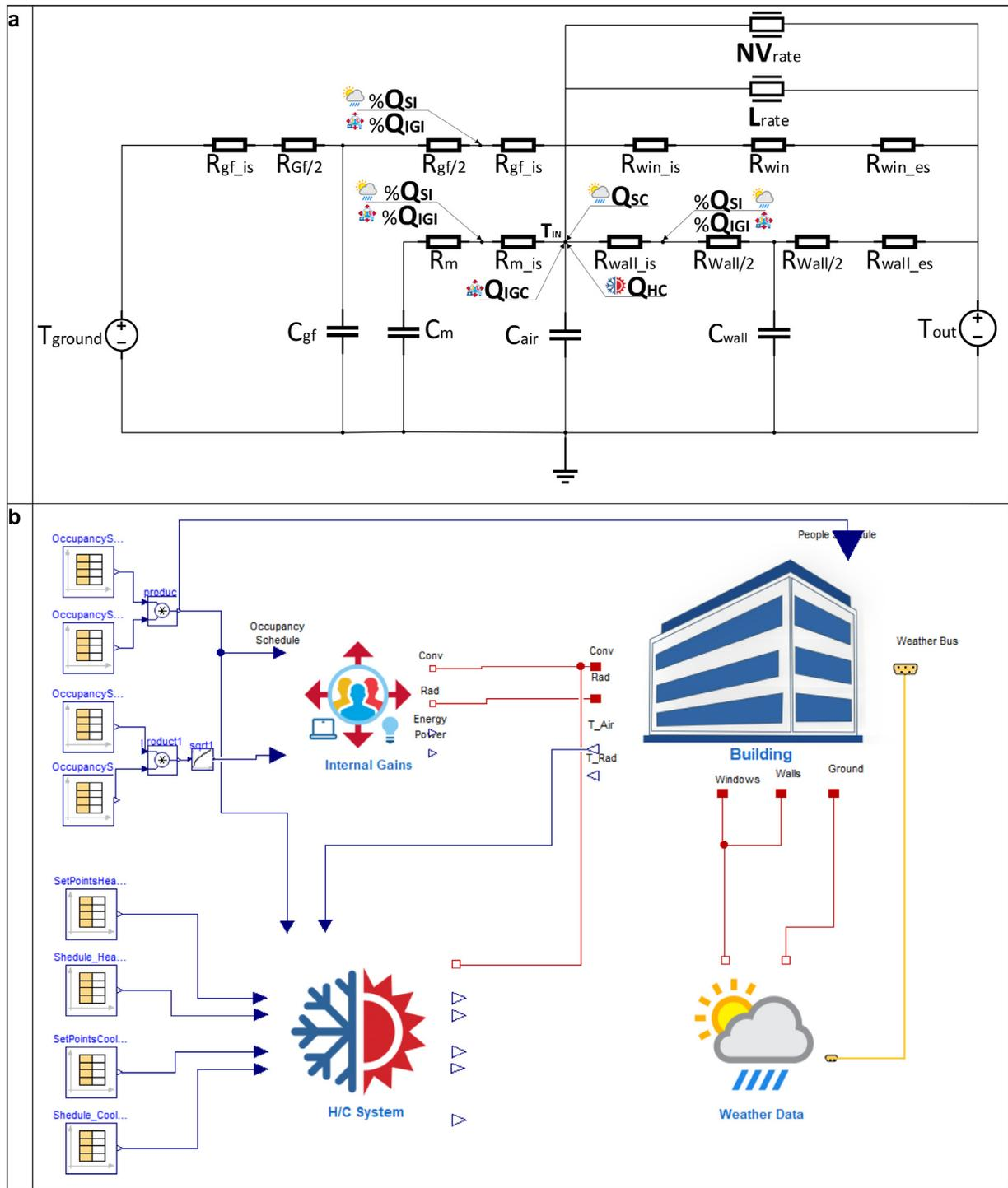

Fig. 2. a) The RC network of the developed ROM and b) the Modelica ROM.

■ Coefficient of Variation of Root Mean Square Error → CV (RMSE) < 20%

$$CV(RMSE) = \frac{1}{\bar{Y}} \sqrt{\frac{\sum_{i=1}^n (\hat{Y}_i - Y_i)^2}{n - 1}} * 100(\%) \tag{2}$$

$$R^2 = \left( \frac{n \cdot \sum_{i=1}^n \hat{Y}_i \cdot Y_i - \sum_{i=1}^n \hat{Y}_i \cdot \sum_{i=1}^n Y_i}{\sqrt{\left( n \cdot \sum_{i=1}^n \hat{Y}_i^2 - \left( \sum_{i=1}^n \hat{Y}_i \right)^2 \right) \left( n \cdot \sum_{i=1}^n Y_i^2 - \left( \sum_{i=1}^n Y_i \right)^2 \right)}} \right)^2 \tag{3}$$

■ Coefficient of Determination → R<sup>2</sup> > 0.75

■ Monthly Deviation < 15%

$$MD = \frac{(\hat{Y}_i - Y_i)}{Y_i} * 100(\%) \quad (4)$$

where:

$\hat{Y}$  is the simulated energy consumption and  $Y$  is the measured energy consumption,  $\bar{Y}$  is the mean of measured energy consumption,  $n$  is the number of data points.

The following Sections 2.2.1 – 2.2.4 provide details of the four main Modelica components.

### 2.3. Internal gains component

The 'internal gains component' was modelled to evaluate the thermal heat gains from people, lighting and equipment in the building. The inputs needed to estimate these parameters included occupancy schedules; maximum internal heat gains from people, lighting and equipment; and stand-by heat gain from the equipment. Furthermore, a Modelica component estimating the electrical consumption of lighting and other equipment was included, and used for calculation of the total energy consumption. This component adjusted the energy consumption by utilising two parameters representing the simultaneous utilisation/efficiency of the lighting and equipment heat gains.

The component divided the heat gains generated by the convective ( $Q_{GC}$ ) and the radiative part ( $Q_{GI}$ ) of the heat.

### 2.4. Heating and cooling system component

The 'heating and cooling system component' was implemented as a thermo-regulated regulated heat gain with an internal control loop. This component was a generic heat source that could be used to represent different types of systems. The component was divided in two parts. The first part (Fig. 3) represented the thermo-regulated heat gain controlled by two Proportional Integral Derivatives (PIDs, a control loop mechanism employing feedback). This allowed to generate concurrently heating and cooling heat gains ( $Q_{HC}$ ) into the building/room. The second part was used to estimate the heating and cooling energy consumption of the system. To estimate the energy consumption, the component used the "Cooling\_Power", "Heating\_Power" and "Equipment\_Power" input of Fig. 3. Additionally, three statistical parameters were included to maximise the efficiency of the calibration procedure.

### 2.5. Building component

The main element of the ROM was the 'building component'. The structure of this component was an extension of the model proposed by Bacher and Madsen[3]. The 'building component' was created using the Modelica language and some elements of the IBPSA Project 1 Library (IBPSA, 2018). It was composed of 14 resistances, 3 capacitances, a solar irradiation component, a natural ventilation component and an air infiltration component. The aforementioned elements were connected to a Modelica MixingVolume element that represented the entire volume of the building. The 'building component' was also connected to the outdoor weather data and thus received inputs such as temperature and solar irradiation through the 'Weather data component'. Finally, the MixingVolume element was connected to the 'internal gains component' and the 'heating and cooling system component' through the radiative and convective heat ports.

The resistances and capacitances in this component could be divided in four groups and they were used to combine all building internal and external envelope. The first assembly ( $C_m, R_m, R_{m1}, R_{m_{is}}$ ) was used to combine the building internal wall and slabs. The second group ( $R_{wall_{es}}, R_{wall}, C_{wall}, R_{wall1}, R_{wall_{is}}$ ) was used to

combine the whole building opaque envelope. The third ( $R_{win_{es}}, R_{win}, R_{win_{is}}$ ) represented the building transparent envelope, and finally the fourth ( $R_{gf_{es}}, R_{gf}, C_{gf}, R_{gf1}, R_{gf_{is}}$ ) was the building ground floor. These elements took the temperature inputs from the 'weather data component'.

The solar irradiation component used two elements of the IBPSA Project 1 Library (IBPSA, 2018) to compute the direct solar irradiation and the diffuse solar irradiation using the anisotropic sky model [33]. The irradiation was then reduced, using the G total value (total amount of solar irradiation entering through the glazing and the solar shading with reference to the total incident radiation) calculated according to the BS EN 13363-1 [6]. The natural ventilation component was modelled using a formula from ASHRAE Fundamentals [1] which was based on temperature and pressure differences between the ambient and the internal volume. Finally, to compute the air infiltration in the building an air leakage component was created based on the IBPSA Project 1 Library (IBPSA, 2018).

### 2.6. Weather data component

The 'weather data component' was a simple data container. The weather data and the ground temperature enclosed in this element were used by the 'building component' and the 'heating and cooling system component'.

### 2.7. Phase 3 – The ROM utilisation

The third phase consisted of the ROM utilisation, as a baseline for the M&V and for the application of different retrofitting scenarios.

According to the IPMVP<sup>®</sup> [9], the energy or water demand savings cannot be directly measured, because savings represent the absence of energy or water consumption/demand. Instead, savings are determined by comparing measured consumption/demand before and after the implementation of a program/retrofit, making suitable adjustments for changes in conditions. The comparison 'before' and 'after' energy consumption/demand should be made on a consistent basis, using the following general M&V equation:

$$\text{Savings} = (\text{Baseline Period Energy} - \text{Reporting Period Energy}) \pm \text{Adjustments} \quad (5)$$

There are several methods and techniques to estimate the Baseline Period Energy. This work utilised the ROM described in the section 2.2 as an innovative OPTION D of the IPMVP<sup>®</sup> [9].

Sections 2.3.1 and 2.3.2 describe the formulas used for calculation of savings and, thus, for the utilisation of the ROM as IPMVP<sup>®</sup> baseline.

### 2.8. IPMVP<sup>®</sup> baseline period energy (Phase 3a)

In order to create the Baseline Period Energy with the ROM, the following formula was used:

$$\text{Savings} = \left( \begin{array}{l} \text{Baseline Period Energy from the Calibrated Model [baseline without ECM]} \\ - \text{Actual Reporting Period Energy [e.g. energy bills]} \\ \pm \text{Calibration Error in the Corresponding Calibration Readings} \end{array} \right) \quad (6)$$

The "Baseline Period Energy from the Calibrated Model" was obtained from the calibrated ROM, which was updated with the data referred to the reporting period. This data included all the independent variables as the weather file, occupancy schedules, equipment schedules, HVAC set points, and HVAC heating/cooling ON-OFF. Furthermore, other inputs to the ROM could be adjusted

when the static factors were modified in the reporting period. These could include the heat gains from building occupants (occupancy type, density), significant equipment problems, lighting levels, etc. Fig. 4 shows the concept of IPMVP<sup>®</sup> savings referred to a ROM where the Reporting Period (green line) is related to the measured data .

2.9. Application of retrofitting scenarios (Phase 3)

The ROM was applied to investigate the possibility of different retrofitting scenarios. In this case, both Reporting Period Energy and Baseline Period Energy were calculated using the ROM.

$$Savings = \text{Baseline Period Energy from the Calibrated Model [without ECM]} - \text{Reporting Period Energy from the Calibrated Model [with ECM]} \tag{7}$$

The “Baseline Period Energy from the Calibrated Model” was calculated as in the previous section (2.3.1), while the “Reporting Period Energy from the Calibrated Model” was calculated by applying Energy Conservation Measures (ECM) to the ROM. In this case,

the ROM was tested only for the application of envelope retrofits, e.g. additional external wall insulation (Section 4.5, [34]; and HVAC simple controls, e.g. changing temperature set points [35]). Fig. 3 shows the application of retrofitting scenarios using a ROM where in this case, the Reporting Period (green line) is related to the ROM simulation.

3. Sant Cugat demonstration buildings

3.1. Buildings description

This research was demonstrated utilising operating buildings in Sant Cugat, Spain, which included a primary school building, a sports pavilion and an administrative building, all constructed in 1975 (Fig. 5).

The relevant building data were collected directly from the BIM model and integrated through an interactive process of interviews and direct communication with the building owners.

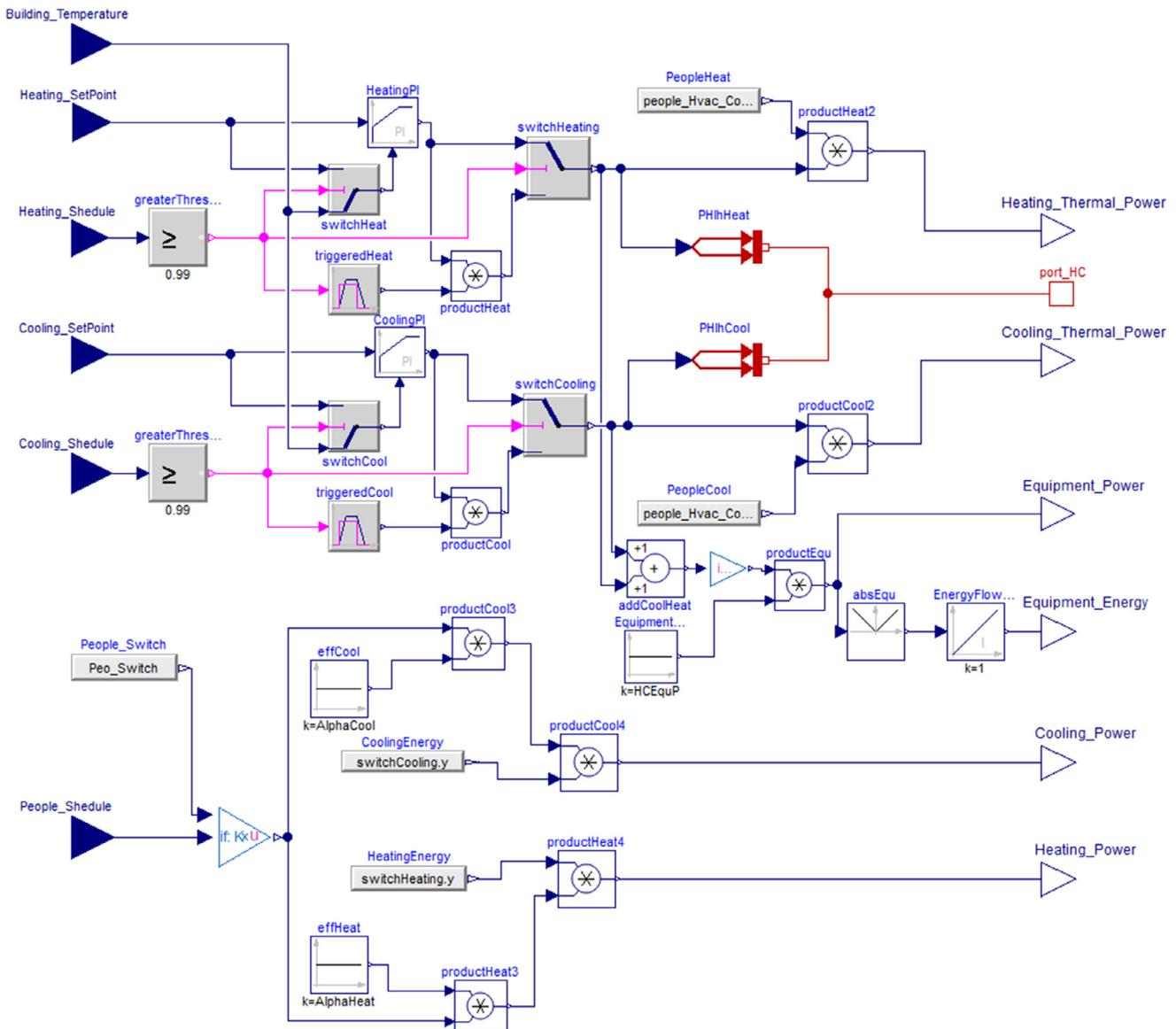

Fig. 3. Heating and Cooling system Modelica component.

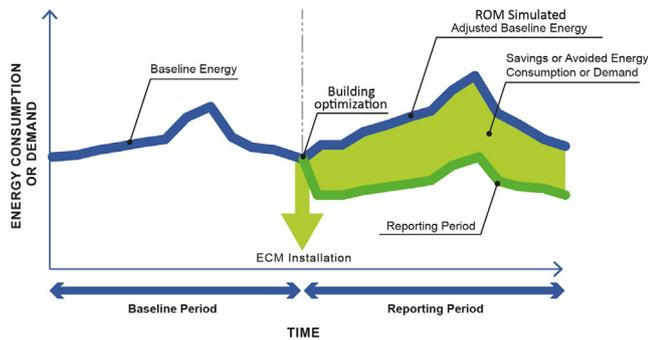

Fig. 4. Savings (or avoided energy consumption) calculated using the ROM for the creation of the baseline energy period. Adapted from [9].

### 3.2. Building fabric

Based on the BIM data, the primary school had a total floor plan area of 2900 m<sup>2</sup> distributed between two floors (3.5 m high). The administrative building’s floor plan area was 280 m<sup>2</sup> with an average floor to ceiling height of 3.5 m, and the sport pavilion had a floor plan area of 450 m<sup>2</sup> with an average floor to ceiling height of 5.9 m.

The BIM provided specifications for walls, floors, roofs and openings, including surface area, materials and U-values. The U-Values not specified in the BIM were calculated using ROMPar (Section 4.1). There were five different types of external walls and two types of internal partitions in the demonstration buildings (Table 1).

The floor slabs, including the ground floor slab, were made of concrete (U-value of 2.66 W/m<sup>2</sup>K). The roof was a steel structure clad with clay tiles (total surface area of 2200 m<sup>2</sup>).

The windows were double glazed with a PVC frame and equipped with manually operable shutters. The total surface area of the windows was 610 m<sup>2</sup>. The 80% of the window openings faced north–south direction and the remaining 20% faced east–west direction.

### 3.3. Occupancy schedules and internal gain

Occupancy schedules were estimated by direct communication with buildings owners. The buildings were occupied between Monday and Friday, from the middle of September to the middle of June, depending on the year. The primary school was occupied by 55 people between 7.30am and 9.30am, 350 people between 9am and 4.30 pm and 45 people between 4.30 pm and 6 pm. The administrative building was occupied by 8 people between 7am and 6 pm. The sport pavilion was occupied on average by 52 people between 9am and 4.30 pm and by 35 people between 4.30 pm and 6 pm. The internal gains from lighting, plug loads and people were calculated using the ROMPar.

Due to the Covid-19 lockdown the buildings were closed between 11th March 2020 and 1st June 2020. During this period

Table 1  
External walls and partitions specification.

Walls and partitions	Area [m <sup>2</sup> ]	U-Value [W/(m <sup>2</sup> .K)]
Hollow bricks partition – 12 cm	115.05	4.5
Hollow bricks partition – 10 cm	1925.27	5.40
Concrete wall – 15 cm	40.67	–
Brick wall – 30 cm	67.37	1.80
Brick wall – 40 cm	277.66	1.35
Brick wall – 50 cm	220.68	1.08
School Brick wall – 30 cm	2589.41	0.83

there was no activity in the building. These considerations were included in the creation of the internal gain schedules of the ROM (people, lighting and equipment).

### 3.4. Heating systems

The demonstration buildings were equipped with three non-condensing natural gas boilers (thermal capacity of 1 × 125 kW and 2 × 110 kW), with the fourth boiler (110 kW) kept in reserve. The heat was distributed by radiators with a maximum supply temperature of 70 °C.

Cooling units were only present in the sport pavilion and in the computer labs of the primary school. The sport pavilion was equipped with three 12 kW air source heat pump units and four 5.2 kW split units, while the computer labs were equipped with four 3.3 kW dual split units. The heating season generally occurred between the end of October and the middle of April, depending on the year. The indoor set point temperatures were constant, i.e. at 22 °C for heating and 26 °C for cooling.

The heating schedules were estimated through direct communication with owners (for the years 2017–2019) and deducted from the Ecoscada cloud Building Energy Management System (BEMS) for 2020 (more details in section 3.1.5).

From the beginning of the Covid-19 lockdown (11th March 2020) until the closure of the heating system (16th April 2020) the circuit was kept open but the setpoint temperature was decreased by 1 °C (i.e. 21 °C).

### 3.5. Buildings retrofit

Since 2018, the buildings had been retrofitted with several ECMs. A new lighting system based on LED bulbs and photovoltaic (PV) panels were installed in December 2018. All of the external opaque building envelope was retrofitted with an external thermal insulation composite system (ETICS). These retrofitting works started in February 2019 and finished in July 2019. The U-values of external walls pre- and post-retrofit are shown in Table 2.

### 3.6. Ecoscada BEMS

In November 2019, a smart cloud Building Energy Management System (BEMS) called Ecoscada was installed in the demonstration buildings. With the Cloud-based BEMS several meter readings have been collected, such as buildings electricity consumption, gas consumption of the boilers, and indoor and outdoor air temperature. The measured BEMS data was utilised to create the 2020 weather file, ROM schedules and utility bills’ analysis.

### 3.7. Weather data

The Sant Cugat average ambient air temperature ranges between 20 and 29 °C in summer, to 7–16 °C in winter. The MERRA 2 application [18] was utilised to extract the 2017 – 2019 weather data, including ambient air temperature, relative humidity, barometric pressure and solar irradiation needed for ROM development.

Table 2  
U-Values for walls pre- and post-retrofit.

Walls	Area [m <sup>2</sup> ]	U-Value [W/(m <sup>2</sup> .K)]	
		Pre	Post
Retrofitted concrete wall – 15 cm	40.67	6.5	0.29
School retrofitted brick wall – 30 cm	2589.41	0.83	0.27

The 2020 weather data was extracted from the ECOSCADA BEMS (4.1.5) and from the MERRA 2 application. The Elements platform (Big Ladder [5]) was used to create the standardised weather file (.epw). Then, the .epw file was converted into a .mos file to allow its usage in the ROM.

### 3.8. Utility bills analysis

A full review of energy bills retrieved for electricity and gas consumption for the demonstration buildings was carried out. Gas and electricity bills of the facility were analysed for the years 2017 to 2019 and for the year 2020 the Ecoscada BEMS data was used. Table 3 shows monthly electrical energy bills and monthly gas readings used to develop the M&V baseline in the ROM and to estimate energy savings generated by ECMs.

Table 3, shows the electricity consumption in 2019 was 30,000 kWh lower than the previous year (2018), due to the installation of LED bulbs and photovoltaic (PV) panels in December 2018.

## 4. Results

### 4.1. Rompar – parameters calculation (Phase 1)

Following the research methodology (Section 2), ROMPar was used to calculate parameters required as input to the Modelica ROM (Table 4). These parameters were based on 2017 data collected from Sant Cugat demonstration buildings. Five underlined parameters in Table 4, i.e.  $L_{RATE}$ ,  $\alpha_{Lig}$ ,  $\alpha_{Equ}$ ,  $\alpha_{Heat}$ ,  $\alpha_{Cool}$ , were deemed for the calibration. Following the Giretti et al. [19] assumptions, these parameters were chosen, because they were of a higher degree of uncertainty, i.e. a low level of reliability. All other parameters were taken from the project data, the on-site surveys and technical data-sheets, and thus they were characterised by a high and medium level of reliability. In particular: the leakage rate ( $L_{RATE}$ ) was approximated and then used in the calibration process because it could not be easily measured. The Alpha equipment and lighting ( $\alpha_{Lig}$ ,  $\alpha_{Equ}$ ) were used in the calibration to consider the uncertainty due to the internal gain values, and to take into account the average efficiency/utilisation of the equipment and lighting. Finally, the Alpha Heating and Cooling ( $\alpha_{Heat}$ ,  $\alpha_{Cool}$ ) were chosen because these values represent the average efficiency/utilisation of the system installed in the building. In reality, the efficiency/utilisation of lighting, equipment, heating and cooling varied depending on the zone within the Sant Cugat demonstration buildings, but the ROM considered a single volume with a single schedule for each of the heat gains.

**Table 3**  
Monthly electricity and natural gas consumption of the demonstration buildings.

	Electricity [kWh]				Natural gas [kWh]			
	2017	2018	2019	2020	2017	2018	2019	2020
<b>Jan</b>	12,766	11,659	9,472	7,670	60,237	62,680	57,377	35,139
<b>Feb</b>	11,335	10,571	9,406	6,766	34,196	58,647	50,889	25,979
<b>Mar</b>	11,041	9,997	7,745	4,306	22,732	29,459	27,538	20,808
<b>Apr</b>	8,360	9,176	6,512	2,602	13,712	19,086	21,837	5,572
<b>May</b>	10,146	9,507	5,846	2,236	6,386	4,069	11,490	242
<b>Jun</b>	9,066	8,702	5,590	1,834	n/a	n/a	n/a	n/a
<b>Jul</b>	6,644	5,833	4,740		n/a	n/a	n/a	
<b>Aug</b>	6,611	4,241	3,049		n/a	n/a	n/a	
<b>Sep</b>	9,548	7,733	4,928		n/a	n/a	n/a	
<b>Oct</b>	10,970	9,195	6,932		n/a	7949	623	
<b>Nov</b>	10,800	9,954	7,800		23,297	22,179	22,038	
<b>Dec</b>	9,634	8,427	7,129		40,607	35,773	18,921	
<b>Tot</b>	<b>116,921</b>	<b>104,995</b>	<b>72,020</b>		<b>201,167</b>	<b>239,842</b>	<b>210,713</b>	

### 4.2. ROM simulation and calibration (Phase 2)

The ROM, which included calculated parameters (Table 4) was calibrated using the 2017 Sant Cugat data. The 2017 data included schedules for occupancy, equipment, cooling, heating and set points.

The calibration consisted of an iterative process of changing five uncertain parameters (Table 5) until the IPMVP<sup>®</sup> statistical indices were respected. The model results were compared with the measured gas readings and electrical bills from the demonstration buildings using the statistical indices (equations 1–4). The details of this calibration process can be found in Piccinini [34].

Table 5 shows the final values of five uncertain parameter in the calibrated 2017 ROM.

The calibrated 2017 ROM satisfied all IPMVP<sup>®</sup> calibration criteria (Table 6), with yearly precision of 4.14% and 3.65% for gas and electricity consumption respectively, at 90% level of confidence.

Fig. 6 outlines the simulated energy consumption against the measured energy consumption with the associated monthly deviation. There is no data shown for gas consumption between June and October 2017 (Fig. 6a) because, as explained in 3.1.3, the heating system was turned off during that period. The results show that calibrated ROM was capable also of meeting the IPMVP<sup>®</sup> monthly deviation criteria within the 15% range.

### 4.3. ROM validation

The calibrated 2017 ROM of Sant Cugat demonstration buildings was validated utilising the 2018 data. The parameters used in the 2018 ROM were the same as those used in the 2017 calibrated ROM (Tables 4 and 5), while the weather file, internal gains schedules and system schedules were updated with the 2018 data.

Table 7 shows the results of the 2018 ROM met the calibration criteria. This demonstrated the capability of ROMs to forecast electrical and gas energy consumption in buildings, in a scenario where some of the technical information was incomplete and uncertainties in model parameters were present.

Fig. 7a shows the simulated energy consumption against the measured energy consumption with the associated monthly deviation for the year 2018. Fig. 7a shows two anomalies where the monthly deviation was over the 15% limit.

The first anomaly occurred in August where the ROM overestimated the electrical consumption. During this period the building was closed, and an overestimation could have been generated by different schedules considered for the equipment or the lighting in the ROM. There was no Ecoscada BMS data available for that period, thus, the real schedule in operating building could not have been verified.

**Table 4**  
ROM parameters for the Sant Cugat demonstrator based on 2017 data.

Value	Description	Unit	Value	Description	Unit		
Latitude	41.4776	Building/room latitude	-	$R_m$	1.17E-04	Partitions resistance	K/W
Volume	13,547	Building/room volume	$m^3$	$C_m$	2.52E + 09	Partitions capacitance	J/K
AWin <sub>South</sub>	255.75	Total windows surfaces at south	$m^2$	$R_{gf\_IS}$	6.57E-05	Ground floor internal resistance	K/W
AWin <sub>North</sub>	237.51	Total windows surfaces at north	$m^2$	$R_{gf}$	2.83E-04	Ground floor resistance	K/W
AWin <sub>West</sub>	60.9	Total windows surfaces at west	$m^2$	$R_{gf\_ES}$	2.02E-05	Ground floor external resistance	K/W
AWin <sub>East</sub>	54.81	Total windows surfaces at east	$m^2$	$C_{gf}$	1.51E + 09	Ground floor capacitance	J/K
AWin <sub>Roof</sub>	0	Total roof windows surfaces	-	$L\_RATE$	3	Infiltration rate	kg/s
GtotW <sub>South</sub>	0.75	G-total values windows south	-	WeaFile	S.Cugat	Weather data file	-
GtotW <sub>North</sub>	0.75	G-total values windows north	-	GroundT	20	Ground temperature	°C
GtotW <sub>West</sub>	0.75	G-total values windows west	-	MLoad <sub>Peo</sub>	32,756	Heat gain per people	W
GtotW <sub>East</sub>	0.75	G-total values windows east	-	MLoad <sub>Lig</sub>	42,280	Heat gain per lighting	W
GtotW <sub>Roof</sub>	0	G-total values windows roof	-	MLoad <sub>Equ</sub>	6724	Heat gain per equipment	W
Ratio <sub>-m</sub>	0.381	Ratio of the internal partition	-	SBLoad	0	Internal gains StandBy consumption	W
Ratio <sub>-wall</sub>	0.424	Ratio of the external walls	-	$\alpha_{Lig}$	1 (1 to 3)	Lighting efficiency/utilization	-
Ratio <sub>-win</sub>	0.046	Ratio of the external windows	-	$\alpha_{Equ}$	1 (1 to 3)	Equipment efficiency/utilization	-
Ratio <sub>-gf</sub>	0.149	Ratio of the ground floor	-	MCoolP	70,000	Maximum system cooling Power	W
$R_{wall\_IS}$	2.31E-05	Walls internal surface resistance	K/W	MHeatP	345,000	Maximum system heating power	W
$R_{wall}$	4.9E-04	Walls resistance	K/W	HCEquP	8000	system equipment power	W
$R_{wall\_ES}$	7.10E-06	Walls external surface resistance	K/W	SBHeat	5000	StandBy consumption heating	W
$C_{wall}$	7.99E + 08	Walls capacitance	J/K	SBCool	0	StandBy consumption cooling	W
$R_{win\_IS}$	2.13E-04	Glazing internal surface resistance	K/W	Peo <sub>-Switch</sub>	FALSE	People control switch	-
$R_{win}$	6.33E-04	Glazing resistance	K/W	$\alpha_{Peo}$	1 (1 to 5)	People system influence	-
$R_{win\_ES}$	6.56E-05	Glazing external surface resistance	K/W	$\alpha_{Heat}$	1 (1 to 5)	Heating system efficiency/utilization	-
$R_{m\_IS}$	2.56E-05	Partitions internal surface resistance	K/W	$\alpha_{Cool}$	1 (1 to 5)	Cooling system efficiency/utilization	-

*A = Surface*  
*Win or W = Windows*  
*Gtot = G total value*  
*m = Medium (partition, internal slabs)*  
*gf = Ground floor*  
*R = Resistance*  
*C = Capacitance*

*IS = Internal Surface*  
*ES = External Surface*  
*L = Leakage*  
*T = Temperature*  
*M = Maximum*  
*Load = Heat Gain*  
*Peo = People*

*Lig = Lighting*  
*Equ = Equipment*  
*P = Power*  
*SB = Stand By*  
*HC = Heating and Cooling*  
*Alpha = Unknown Calibration Parameter*

**Table 5**  
Parameters used in the calibrated 2017 ROM (Piccinini et al., 2020).

Parameter	Description	Value
$\alpha_{Heat}$	Heating - efficiency/utilisation	2.2
$\alpha_{Cool}$	Cooling - efficiency/utilisation	0.2
$L\_rate$	Air infiltration rate [kg/s]	3
$\alpha_{Equ}$	Equipment - efficiency/utilisation	1.1
$\alpha_{Lig}$	Lighting - efficiency/utilisation	0.5

**Table 6**  
IPMVP® statistical indices of the calibrated 2017 ROM (Piccinini et al., 2020).

Model 2017	ROM Gas	ROM Ele
Total energy	96,302 kWh	115,011 kWh
NMBE	-0.67%	1.31%
CV(RMSE)	7.98%	7.08%
R <sup>2</sup>	0.99	0.89
Monthly precision @90%	±14.35% (±1152 kWh)	±12.66% (±1213 kWh)

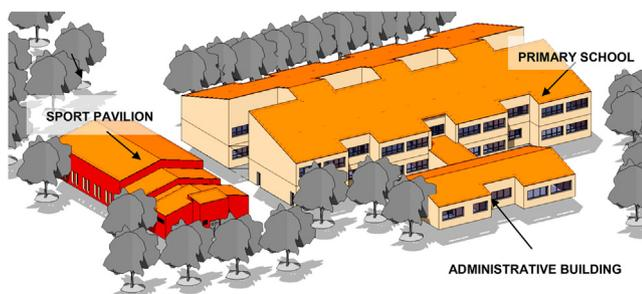

**Fig. 5.** BIM model of the demonstration buildings.

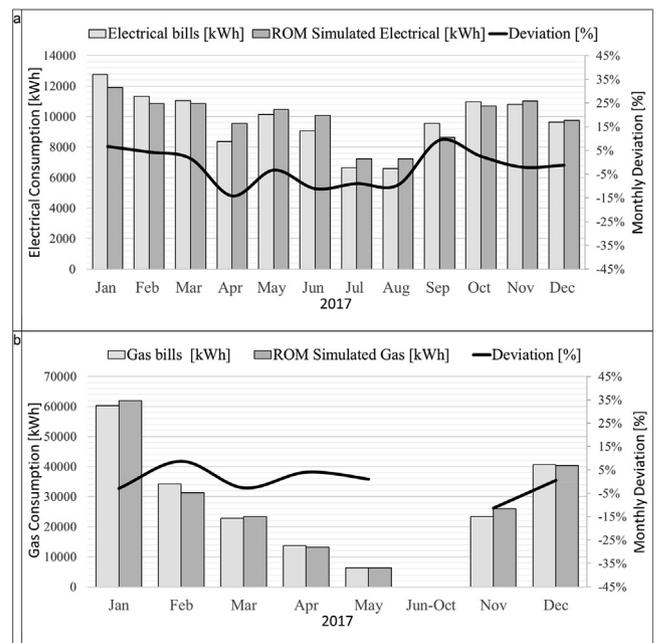

**Fig. 6.** Measured and simulated electrical (a) and gas (b) consumption with monthly deviation for year 2017 [36].

The second anomaly in December 2018 was due to the PV panels and the LED bulbs installed during that month. This reduction reflected savings that were calculated in section 5.4 for the year 2019.

Fig. 7b shows the measured and simulated gas consumption with monthly deviation for the year 2018. Also in this case there was an anomaly in May 2018, where the monthly deviation

**Table 7**  
IPMVP® statistical indices of the calibrated 2018 ROM (Piccinini et al., 2020).

Model 2018	ROM Gas	ROM Ele
Total energy	96,302 kWh	116,410 kWh
NMBE	4.99	3.47
CV(RMSE)	9.77	8.81
R <sup>2</sup>	0.98	0.83

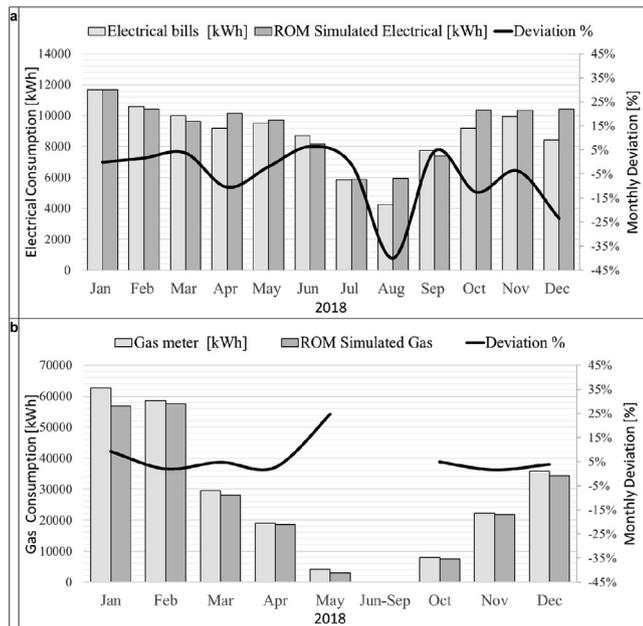

**Fig. 7.** Measured and simulated electrical (a) and gas (b) consumption with monthly deviation for year 2018.

reached 25%. In this case the high value of monthly deviation was due the low value of measured gas consumption in May 2018 (as calculated from equation (4)).

4.4. IPMVP® baseline (Phase 3a)

In order to demonstrate the capability of ROM to be used as an IPMVP® Baseline Period Energy (BPE) and, thus, to estimate energy savings using the IPMVP® formula (Section 2.3.2), the calibrated ROM was used to create gas and electricity baseline energy for year 2019. Also in this case, the updated data were the weather file, internal gains schedules and system schedules. All remaining parameters were kept the same as in the calibrated 2017 ROM.

Fig. 8a displays the ROM Adjusted BPE in comparison with the Reporting Period Energy (RPE) for electricity. ROM Adjusted BPE is a baseline period energy consumption modified as part of routine and non-routine adjustments to account for changes in the reporting period [9]. In other words, it is building’s energy consumption as if the ECMs were not carried out. ROM Adjusted BPE allows to calculate the actual energy savings taking into account the boundary condition (e.g. weather file, different occupancy, etc.) of the year considered. Fig. 8a shows the savings generated (avoided energy consumption), which were due to the new PV panels system and LED bulbs installed in December 2018 (ECMs installation).

The savings in year 2019 and 2020 peaked in the summer period (Fig. 8a), probably due to a higher (than in other seasons) electrical energy production from PV panels.

Fig. 8a shows a reduction of the adjusted BPE consumption in the year 2020 compared to the year 2019. The buildings were closed from the 11th of March 2020 due to the Covid-19 lockdown and the ROM schedules were modified to reflect the closure. For

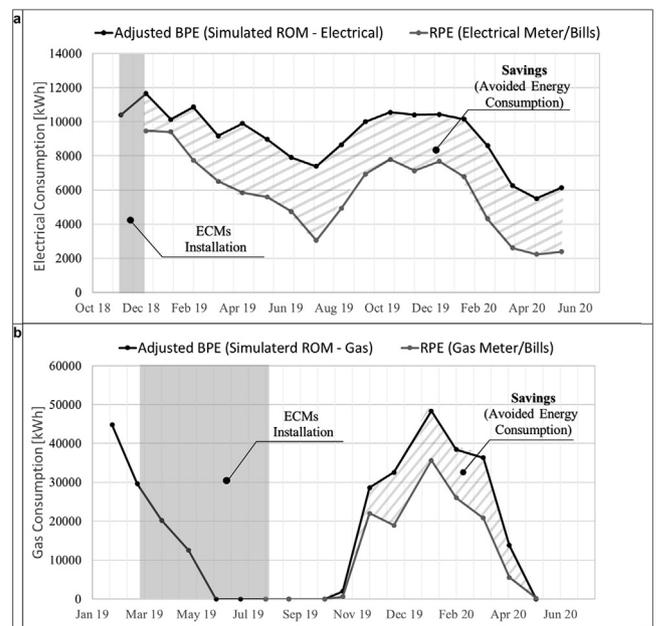

**Fig. 8.** ROM Adjusted (a) electrical and (b) gas BPE in comparison with the electrical and gas RPE for year 2019.

this reason, the consumption generated by the BPE in 2020 was lower than the previous year.

Therefore, the ROM allowed for calculation of the avoided energy consumption from the installation of the PV panels and LED bulbs carried out in December 2018, taking into consideration all the boundary conditions. Thus, with a 90% level of confidence, it was concluded that the ECMs in Sant Cugat demonstration buildings generated the electrical energy savings of 35,853 kWh ± 4,198 kWh (11.7%) over the last 12 months of the analysis (from July 2019 to June 2020).

Fig. 8b displays the ROM Adjusted BPE in comparison to the Reporting Period Energy (RPE) for gas consumption over one year of heating between June 2019 and June 2020. Between February and July 2019, Sant Cugat demonstration buildings underwent the installation of external insulation. Thus, with a 90% level of confidence, it can be noted that the effects of this ECM generated yearly savings of 65,821 kWh ± 3,987 kWh (6.1%) (for the period between June 2019 and June 2020).

4.5. Ecms saving estimation (Phase 3b)

In order to test the ROM in terms of retrofit packages, the external wall insulation applied to the building between February and August 2019 was also included in the model, and ROMPar was updated accordingly, with the new material thermal resistances. Table 8 shows new envelope thermal resistances and capacitance calculated by ROMPar.

Fig. 9 shows the measured (Ecoscada BEMS) and ROM simulated (with insulation) gas consumption with the absolute value difference for year 2020. The figure shows the good capability of the ROM in estimating the energy savings due to envelope ECMs. The absolute difference was under 10%. Thus, the ROM could be used also as a method to test the best retrofit envelope package to apply to the building.

4.6. ROM daily and hourly heating demand

The ROM modified with the new insulation applied (Section 3.1.4), was investigated to understand the model’s capability in simulating daily and hourly gas consumption.

**Table 8**  
Resistances and capacitance of the retrofitted external wall.

	Baseline Values	Value	Unit
Rwall_is	2.31E-05	2.31E-05	K/W
Rwall	4.9E-04	1.18E-03	K/W
Rwall_es	7.10E-06	7.10E-06	K/W
Cwall	7.99E + 08	1.18E + 09	J/K

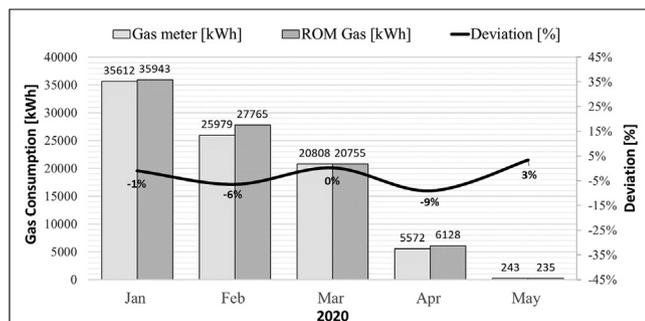

**Fig. 9.** Comparison of the monthly measured and ROM simulated gas consumption.

Firstly, the hourly data was downloaded from Ecoscada and combined to calculate measured daily gas consumption (kWh). The measured daily gas consumption was then compared with the simulated daily gas consumption (Fig. 10).

In the four-month period (January 2020 to end of April 2020), the ROM achieved the accuracy limits of daily NMBE of 1.8% and CV-RMSE of 24.0%. The absolute deviation was below 30% on most of the days (exceeding 30% on seven occasions)

Since the measurement campaign was conducted during the normal use of the building, this could have caused some deviation due to the unexpected variation in both internal and external loads (e.g. unexpected windows' openings, changes in cloud coverage, system schedules). Overall, the low values of NMBE and CV-RMSE indicated the building model could be considered accurate to estimate daily gas consumption.

In order to investigate the source of the deviations, the two highest absolute deviations were considered. The first concerned the 19th January 2020 when the absolute deviation was equal to 100%; the second concerned the 12th February 2020 when the absolute deviation was 68%.

Fig. 11 shows the comparison of the daily gas consumption for three weeks of January 2020 where the first anomaly occurred on 19th January 2020. That day, the ROM underestimated the gas consumption because, in the model, the HVAC schedule was assumed closed during the weekend; however, in reality the boiler was working.

Fig. 12 shows the comparison of measured and ROM simulated gas consumption including outdoor temperature, showing the second highest absolute deviation that occurred on the 12th February 2020.

In this case, the ROM overestimated the gas consumption. On 12th February 2020, the outdoor temperature was lower than the other days that week. Thus, the ROM reacted with an increment in gas consumption, while the measured gas consumption was lower than the other days. This could have been caused by many factors both from the ROM side (poor ability to simulate the thermal inertia of the building) and from the building side (some radiators were closed, unusual increment in the internal gain).

In order to validate the calibration procedure and to investigate the ROM's ability to accurately predict indoor temperatures, the measured and simulated indoor air temperatures between January and April 2020 were analysed. Fig. 13 shows measured (Ecoscada) and ROM simulated daily-average indoor air temperature, with an absolute daily temperature difference indicated.

Fig. 13 shows the measured and simulated daily-average indoor air temperatures. The dotted grey line representing the difference between the two temperature values (measured and simulated) was often below 1.5 °C absolute difference.

Thus, the comparison of measured and ROM simulated indoor air temperatures (Fig. 13) showed that the calibrated model accurately predicted daily-average indoor air temperatures; thus, it could be used for the creation of the IPMVP® baseline energy consumption.

**5. Conclusions**

EPC can accelerate investment in cost-effective ECMs for existing buildings. However, there are many risks and barriers that slow down the uptake of EPC.

The literature review carried out as part of this research demonstrated that M&V and, in particular the IPMVP®, have the potential to reduce some of the EPC barriers. However, the application of the M&V protocol in retrofitting of existing buildings is often complex due to limited and uncertain information about the buildings.

In order to address the challenges of utilising M&V IPMVP® in building retrofit, and to enhance the uptake of EPC, the research presented here developed a novel ROM technology framework that can be used for (i) systematic quantification of energy savings (avoided energy consumption) achieved through ECMs and (ii) direct estimation of energy savings through the investigation of different envelope retrofit scenarios.

The utilisation of this novel ROM framework enables calculation of energy savings due to ECMs based on a limited number of input parameters. This results in a grey box model representation of an

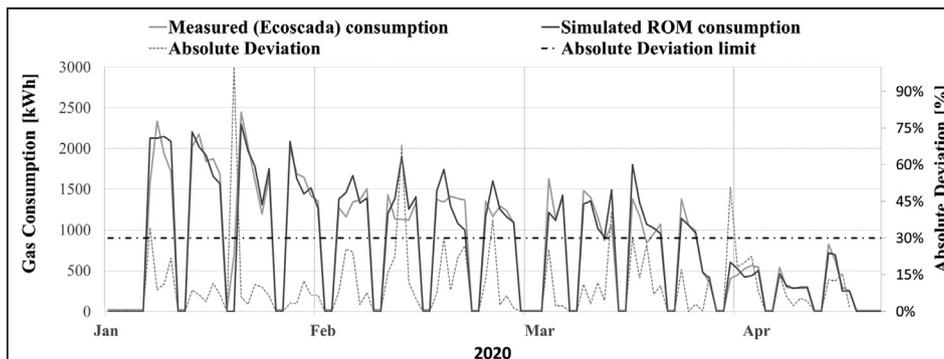

**Fig. 10.** Comparison of the daily measured (boiler gas meter) and ROM simulated gas consumption.

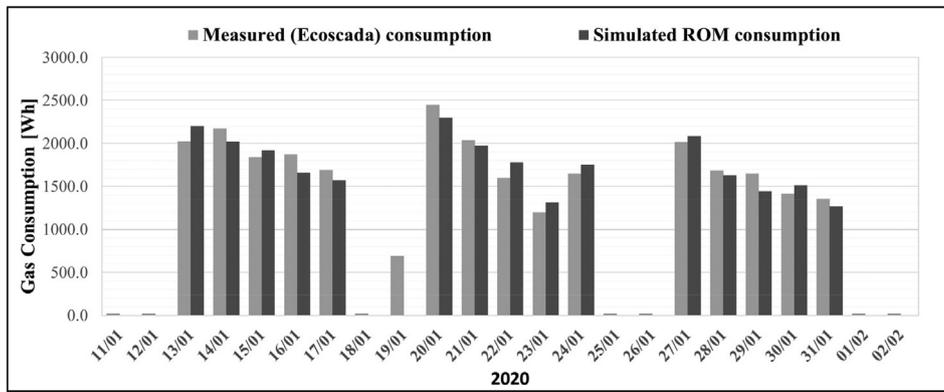

Fig. 11. Comparison of the measured and ROM simulated daily gas consumption for three weeks in January 2020.

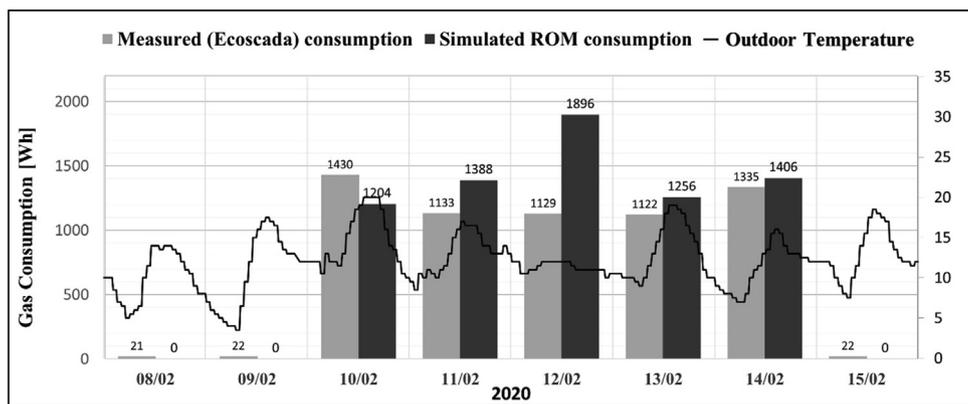

Fig. 12. Comparison of measured and ROM simulated daily gas consumption with outdoor temperature for the second week of February 2020.

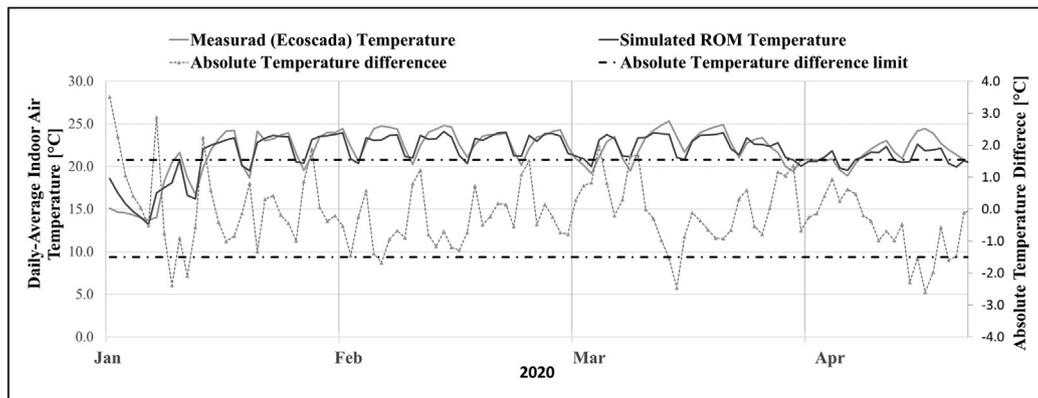

Fig. 13. Comparison of measured and ROM simulated daily-average indoor air temperature, with absolute temperature difference, for 2020.

existing building, which is resource efficient, i.e. requires less computational time and power than white box models and allows for investigation of different retrofit scenarios.

The ROM technology framework was demonstrated on the operating educational buildings located in Sant Cugat, Spain. Measured data (2017–2020) supported the development, validation and calibration of a ROM which represented demonstration buildings before and after the installation of ECMs, such as energy efficient lighting, PV panels and envelope retrofits.

Firstly, the calibrated ROM was used to systematically quantify energy savings (avoided energy consumption) achieved through ECMs, utilising monthly BPE of gas and electricity (2019–2020).

The comparison of the ROM BPE and the RPE (measured data, including electricity bills) showed that between July 2019 and June 2020 (12 months) the ECMs (LED lighting, PV panels) resulted in savings of 35,853 kWh ± 4,198 kWh (11.7%) in gas consumption, and 65,821 kWh ± 3,987 kWh (6.1%) in electricity consumption, estimated with 90% level of confidence, equivalent to €2,058 and €9,285 monetary savings in gas and electricity consumption respectively (calculated as: 35,853 kWh – 4,198 kWh = 31,655 kWh, 31,655 kWh × 0.065 €/kWh = €2,058; and 65,821 kWh – 3,987 kWh = 61,834 kWh, 61,834 kWh × 0.15 €/kWh = €9,285; unit prices based on the electricity and gas bills of the pilot building in June 2020).

Secondly, the calibrated ROM was used to directly estimate energy savings due to building envelope retrofit (installed between February 2019 and July 2019). The results of monthly gas consumption showed ROM's accuracy in estimating energy savings due to envelope ECM's (with difference between measured and simulated gas consumption below 10%).

Finally, the ROM was utilised to test its capability in forecasting daily and hourly heating demand and indoor air temperature. The ROM proved accurate in its predictions, with a NMBE of 1.8% and a CV-RMSE of 24.0%. The difference between measured and simulated daily average indoor air temperatures did not exceed 1.5 °C.

This research demonstrated the potential of applying this novel ROM technology framework to multiple and complex buildings to estimate monthly energy savings due to ECMs. Moreover, the daily and hourly study showed the possibility of extending the framework to daily analysis and the potential of using ROM to design HVAC systems, and to analyse energy consumption patterns after a retrofit action.

### Declaration of Competing Interest

The authors declare that they have no known competing financial interests or personal relationships that could have appeared to influence the work reported in this paper.

### Acknowledgements

This research work was funded by the Irish Research Council (IRC) - R2M Solution S.r.l Enterprise Partnership Scheme Postgraduate Scholarship 2017 (project ID EPSPG/2017/359). This project was partially funded by the European Union under the Horizon 2020 GEOFIT project (Grant agreement No. 792210).

### References

- [1] ASHRAE, *ASHRAE handbook: Fundamentals*, American Society of Heating, Refrigerating and Air-Conditioning Engineers, Atlanta, GA, 2013.
- [2] E. Augustins, D. Jaunzems, C. Rochas, A. Kamenders, Managing energy efficiency of buildings: analysis of ESCO experience in Latvia, *Energy Procedia* 147 (2018) 614–623, <https://doi.org/10.1016/j.egypro.2018.07.079>.
- [3] P. Bacher, H. Madsen, Identifying suitable models for the heat dynamics of buildings, *Energy Build.* 43 (7) (2011) 1511–1522, <https://doi.org/10.1016/j.enbuild.2011.02.005>.
- [4] T. Berthou, P. Stabat, R. Salvazet, D. Marchio, Development and validation of a gray box model to predict thermal behavior of occupied office buildings, *Energy Build.* 74 (2014) 91–100, <https://doi.org/10.1016/j.enbuild.2014.01.038>.
- [5] Big Ladder Software (2020). Elements - custom weather files platform. Available online at: <https://bigladdersoftware.com/projects/elements/>.
- [6] BSI (2003). BS EN 13363-1:2003 - Solar protection devices combined with glazing. Calculation of solar and light transmittance. Simplified method. British Standards Institution. Available online at: <https://shop.bsigroup.com/en/ProductDetail/?pid=000000000030159672>.
- [7] D. Systèmes Dymola Systems Engineering. Available online at 2020.
- [8] E3P (2020). EPC - Energy Performance Contracting. Available online at: <https://e3p.jrc.ec.europa.eu/articles/energy-performance-contracting>.
- [9] EVO, 2016. Efficiency Valuation Organization, International Performance Measurement and Verification Protocol Core Concepts. Available online at: <https://evo-world.org/en/products-services-mainmenu-en/protocols/ipmvp>.
- [10] EnergyPlus (2020). The whole building energy simulation program. Available online at: <https://energyplus.net/>.
- [11] EnergyWatch (2020). IPMVP® Options. Available at: <https://energywatch-inc.com/ipmvp-options/>.
- [12] eQUEST (2020). The QUick Energy Simulation Tool. Available online at: <http://www.doe2.com/equest/>.
- [13] European Union (2012). Directive (EU) 2012/27 of the European Parliament and of the Council of 14 November 2012. Available online at: <https://eur-lex.europa.eu/legal-content/EN/TXT/HTML/?uri=CELEX:32012L0027&from=EN>.
- [14] European Union (2018). Directive (EU) 2018/844 of the European Parliament and of the Council of 30 May 2018. Available online at: <https://eur-lex.europa.eu/legal-content/IT/TXT/?uri=CELEX%3A32018L0844>.
- [15] A. Foucqier, S. Robert, F. Suard, L. Stéphane, A. Jay, State of the art in building modelling and energy performances prediction: a review, *Renew. Sustain. Energy Rev.* 23 (2013) 272–288, <https://doi.org/10.1016/j.rser.2013.03.004>.

- [16] P. Fritzsou, V. Engelson, Modelica – A unified object-oriented language for system modeling and simulation, *Lect. Notes Comput. Sci.* 1445 (1998) 67–90, <https://doi.org/10.1007/BFb0054087>.
- [17] S.F. Fux, A. Ashouri, M.J. Benz, L. Guzzella, EKF based self-adaptive thermal model for a passive house, *Energy Build.* 68C (2014) 811–817, <https://doi.org/10.1016/j.enbuild.2012.06.016>.
- [18] Ronald Gelaro, Will McCarty, Max J. Suárez, Ricardo Todling, Andrea Molod, Lawrence Takacs, Cynthia A. Randles, Anton Darnenov, Michael G. Bosilovich, Rolf Reichle, Krzysztof Wargan, Lawrence Coy, Richard Cullather, Clara Draper, Santha Akella, Virginie Buchard, Austin Conaty, Arlindo M. da Silva, Wei Gu, Gi-Kong Kim, Randal Koster, Robert Lucchesi, Dagmar Merkova, Jon Eric Nielsen, Gary Partyka, Steven Pawson, William Putman, Michele Rienacker, Siegfried D. Schubert, Meta Sienkiewicz, Bin Zhao, The Modern-Era Retrospective Analysis for Research and Applications, Version 2 (MERRA-2), *J. Clim.* 30 (14) (2017) 5419–5454, <https://doi.org/10.1175/JCLI-D-16-0758.1>.
- [19] A. Giretti, M. Vaccarini, M. Casals, M. Macarulla, A. Fuertes, R.V. Jones, Reduced-order modeling for energy performance contracting, *Energy Build.* 167 (2018) 216–230, <https://doi.org/10.1016/j.enbuild.2018.02.049>.
- [20] E. Hairer, G. Wanner, Stiff differential equations solved by Radau methods, *J. Comput. Appl. Math.* 111 (1–2) (1999) 93–111, [https://doi.org/10.1016/S0377-0427\(99\)00134-X](https://doi.org/10.1016/S0377-0427(99)00134-X).
- [21] H. Harb, N. Boyanov, L. Hernandez, R. Streblov, D. Müller, Development and validation of grey-box models for forecasting the thermal response of occupied buildings, *Energy Build.* 117 (2016) 199–207, <https://doi.org/10.1016/j.enbuild.2016.02.021>.
- [22] IBPSA (2017). IBPSA Project 1 - BIM/GIS and Modelica Framework for building and community energy system design and operation. International Building Performance Simulation Association. Available online at: <https://ibpsa.github.io/project1/>.
- [23] IES (2020). Integrated Environmental Solutions Virtual Environment. Available online at: <https://www.iesve.com/>.
- [24] ISO (2017a). ISO 10777:2017: Thermal performance of windows, doors and shutters – Calculation of thermal transmittance – Part 1: General. Available online at: <https://www.iso.org/standard/67090.html>.
- [25] ISO (2017b). ISO 13370:2017: Thermal performance of buildings – Heat transfer via the ground – Calculation methods. Available online at: <https://www.iso.org/standard/65716.html>.
- [26] ISO (2007). ISO 6946:2007: Building components and building elements. Thermal resistance and thermal transmittance. Calculation method. International Organization for Standardization. Available online at: <https://www.iso.org/standard/40968.html>.
- [27] ISO (2008). ISO 13790:2008: Energy performance of buildings - Calculation of energy use for space heating and cooling. Available at: <http://store.uni.com/catalogo/en-iso-13790-2008/>.
- [28] M. Lauster, J. Teichmann, M. Fuchs, R. Streblov, D. Mueller, Low order thermal network models for dynamic simulations of buildings on city district scale, *Build. Environ.* 73 (2014) 223–231, <https://doi.org/10.1016/j.buildenv.2013.12.016>.
- [29] P. Lee, P.T.I. Lam, W.L. Lee, Risks in energy performance contracting (EPC) projects, *Energy Build.* 92 (2015) 116–127, <https://doi.org/10.1016/j.enbuild.2015.01.054>.
- [30] X. Li, J. Wen, Review of building energy modeling for control and operation, *Renew. Sustain. Energy Rev.* 37 (2014) 517–537, <https://doi.org/10.1016/j.rser.2014.05.056>.
- [31] Modelica Association (2020). Modelica Language. Available at: <https://www.modelica.org/modelicalanguage>.
- [32] Müller, D. et al. (2016). Aixlib – An Open-Source Modelica Library Within The Ilea-Ebc Annex 60 Framework. *BauSIM 2016* 3–9. Doi: 10.1-201612202736.
- [33] R. Perez, P. Ineichen, R. Seals, J. Michalsky, R. Stewart, Modeling daylight availability and irradiance components from direct and global irradiance, *Sol. Energy* 44 (5) (1990) 271–289, [https://doi.org/10.1016/0038-092X\(90\)90055-H](https://doi.org/10.1016/0038-092X(90)90055-H).
- [34] Piccinini, A. et al. (2019a). Development Of A Reduced Order Model For Standard-Based Measurement And Verification To Support ECM. *Proceedings of the 16th IBPSA Conference*, 4180–4187. Doi: 10.26868/25222708.2019.210482.
- [35] Piccinini, A. et al. (2019b). ModSCO. Online Reduced Order Models (ROM) to Address the Performance Gap. *Proceedings of Sustainable Places 2019*, 20(1), 18. Doi: <https://doi.org/10.3390/proceedings2019020018>.
- [36] Piccinini, A. et al. (2020). A novel ROM methodology to support the estimation of the energy savings under the Measurement and Verification protocol. Doi <http://dx.doi.org/10.13025/stsq-xr77zz>.
- [37] Remmen, P. et al. (2018). TEASER: an open tool for urban energy modelling of building stocks, *Journal of Building Performance Simulation*. Taylor and Francis Ltd., 11(1), 84–98. Doi: 10.1080/19401493.2017.1283539.
- [38] G. Reynders, J. Diriken, D. Saelens, Quality of grey-box models and identified parameters as function of the accuracy of input and observation signals, *Energy Build.* 82 (2014) 263–274, <https://doi.org/10.1016/j.enbuild.2014.07.025>.
- [39] G. Reynders, J. Diriken, D. Saelens, Impact of the heat emission system on the identification of grey-box models for residential buildings, *Energy Procedia* 78 (2015) 3300–3305, <https://doi.org/10.1016/j.egypro.2015.11.740>.
- [40] VDI (2012). VDI 6007/1 Calculation of transient thermal response of rooms and buildings; Modelling of rooms. Available at: <https://www.buildup.eu/en/practices/publications/vdi-guideline-vdi-60071-calculation-transient-thermal-response-rooms-and>.