

Concept design of a new portable medical device for lymphedema monitoring - a EIT Health ClinMed Summer School project

Jordi Escuder Tisaire^{1*}, Elena Martín Rodrigo^{1*}, Sofia Ribeiro^{2,3*}, Mariachiara Ricci^{4*}, Juan Sebastian Cuellar^{5*}, Dimitrios Zeugolis^{3,6}, Yves Bayon², Isabel Rocha⁷

¹ *Universitat de Barcelona (UB), Barcelona, Spain*

² *Medtronic, Sofradim Production, Trevooux, France*

³ *Regenerative, Modular & Developmental Engineering Laboratory (REMODEL) National University of Ireland Galway (NUI Galway), Galway, Ireland*

⁴ *Department of Electronic Engineering, University of Rome "Tor Vergata" (Rome), Rome, Italy*

⁵ *Department of Biomechanical Engineering, Delft University of Technology, Delft, The Netherlands*

⁶ *Science Foundation Ireland (SFI) Centre for Research in Medical Devices (CÚRAM) National University of Ireland Galway (NUI Galway), Ireland*

⁷ *Faculty of Medicine and Cardiovascular Centre of University of Lisbon, Portugal*

**These authors contributed equally to this work.*

Keywords: Breast cancer; Bioimpedance; Lymphedema; Screening; Self-monitoring.

Abstract: Lymphedema is a chronic and progressive condition derived from impaired lymphatic system function. Lymphedema is incurable, progressive, disfiguring, disabling and has adverse psychosocial effects. Upper extremity lymphedema is mainly the consequence of breast cancer surgery. Several methods to diagnose lymphedema exist; however, these diagnoses are performed once the disease is already close to an advanced, irreversible stage. There is a need to monitor patients at risk with an efficient device. To solve this unmet need, we propose a portable home-monitoring device for early diagnosis of lymphedema. This paper explores all the aspects of the development of a new medical device, such as the assessment of the clinical need and the state of the art, the specifications for the solution, the definition of the broad outlines of the development plan and some considerations about the usability, the risk analysis, the market and the competitors.

1. CONTEXT

This work was born as a team project developed during ClinMed 2018 summer school. ClinMed is a summer school of EIT Health co-organized by Inserm, Karolinska Institutet, University of Grenoble-Alpes, University of Lisbon, Medtronic, Becton Dickinson and Madopa. This summer school aims to train participants on the technological innovation in health by providing a global vision of the maturation cycle of a medical device, i.e. from the idea to the market, using the concept of experiential learning. After an immersive stage at Rehabilitation service at the Hospital Santa Maria (Lisbon, Portugal) and the Pediatric Cardiology department at the Hospital Santa Marta (Lisbon, Portugal), and in collaboration with the clinicians, a

real clinical need was identified, and its solution explored during the summer school.

2. INTRODUCTION

Lymphedema is a chronic and progressive disorder which causes an accumulation of lymph fluid (swelling) in parts of the body where lymph nodes or lymphatic vessels are damaged or inadequate. It is caused by an accumulation of fluid in the interstitial tissues, due to the inability of the lymphatic system to transport lymph fluid out of the affected area. Lymphedema is classified as primary or secondary. Primary lymphedema is rare, with an estimated prevalence of 1 in 100,000 individuals and is caused by lymphatic vascular anomalies (Grada and Phillips, 2017). Secondary lymphedema is acquired

and arises because of an underlying systemic disease, trauma or surgery (Kayiran et al., 2017).

Women who have undergone surgical or radiation treatment for breast cancer, the most prevalent cancer among women, are at a lifelong risk of developing lymphedema. Some studies report an incidence of lymphedema of 42% among the breast cancer survivors (Norman et al., 2009). Lymphedema is a significant problem in developing countries. It has been reported that lymphedema affects as many as 200 million people worldwide and approximately 3 million people in the United States (Rockson and Rivera, 2008).

The condition may result in physical and psychological consequences, which can negatively impact a woman's quality of life and compromise her emotional well-being. It limits the range of motion, as well as causing feelings of pain, heaviness, and numbness. Psychologically, women may have decreased self-confidence due to a disturbance in body image, and experience negative emotions such as anxiety, frustration, sadness, anger, and increased self-consciousness (Taghian et al., 2014, Torres Lacomba et al., 2010).

Lymphedema usually progresses through four stages. At Stage 0, lymphatic flow is disturbed but there is no apparent edema in the extremities; it is possible to notice a difference in feeling, unusual tiredness, or slight heaviness. At Stage 1, the circumference of the extremities has increased but the edema recedes with elevation because the skin and tissues haven't been permanently damaged. At Stage 2, the edema does not recede with elevation and may present as pitting or nonpitting. Finally, at Stage 3 the affected limb becomes very large and misshapen due to the irreversible fluid collection (International Society of Lymphology, 2003).

There is no cure for lymphedema. Treatments are designed to reduce the swelling and the other symptoms. The treatments include non-surgical (complete decongestive therapy (CDT), compression therapy, advanced pneumatic compression pumps and exercise) and surgical options (physiological and reductive methods), as shown in Table I.

These treatments, however, are only effective at an early-stage of lymphedema (Kayiran et al., 2017, Norman et al., 2009).

Therefore, it is essential to diagnose the condition as soon as possible to prevent or minimize its progression with the appropriate treatment (Network, 2011, Stout et al., 2012). Nowadays there are several methods to diagnose lymphedema, however, most cases arise after the symptoms are

visible meaning the disease is already at an advanced stage that could become irreversible.

Table 1: Lymphedema treatments.

Non-surgical treatments	Surgical treatments
Complete decongestive therapy	Reductive techniques
Manual lymph drainage	Direct excision
Compression therapy	Liposuction
Exercise	Physiological techniques
Skin care	Lymphatic-lymphatic by-pass
Compression garments	Lymphatic-venous by-pass
Advanced pneumatic compression therapy	Lymph node transfer
Laser therapy	

Recent research developments suggest that new methods capable of detecting the underlying deficiencies of the lymphatic transport system could create a future where it is no longer necessary to wait for the patient's symptoms to become severe enough to be detected. Although some of these methods are already available in the market, they are far away to become the new gold standard mainly due to its price. The quality of life of affected people would increase considerably with an early diagnosis and diligent care of the affected limb.

3. STATE OF THE ART

As mentioned previously, lymphedema should be diagnosed as soon as possible. The goal of timely intervention for breast cancer-related lymphedema is decreased edema, smaller limbs, reduced joint aches, muscle pain and tightness, decreased infection rates, heightened patient desire to continue treatment, decreased medical costs, and improved quality of life (Soran et al., 2014). A delayed diagnosis or treatment can result in rapid and unchecked progression of the disease leading to complications, lack of mobility, loss of function and disability, often leading to costly emergency room visits and treatment (O'Toole et al., 2013). It has been proved that progressive action can diagnose lymphedema four times earlier compared to the current diagnosis procedure (Soran et al., 2014, Shih et al., 2009, Brunelle et al., 2015). To sum up, the challenge facing clinicians is that there is no reliable, affordable diagnostic capable of detecting the disease before symptoms of lymphedema develop.

Nowadays lymphedema diagnosis is made in a clinical environment by thorough evaluation and

physical examination, by assessing volume and shape discrepancies and skin changes among the extremities (Tahan et al., 2010, Kim et al., 2016). Volume measurements can be done by including circumferential measurement of the limbs with a non-flexible tape, water displacement or perometry. The perometry works similarly to computer-assisted tomography, but uses infrared light instead X-rays (O'Toole et al., 2013). Unfortunately, these methods do not provide objective data about the localization of the edema or the shape of the extremity, they are time-consuming, difficult to perform and require considerable experience from the clinician. They may be difficult to use in individuals with large, loose skin folds or in those with arthritis who cannot extend their limbs.

New diagnostic approaches include non-invasive measurements (tonometry, bioimpedance spectroscopy) and imaging techniques (lymphoscintigraphy, ultra-sonography, computed tomography, and magnetic resonance imaging) (Kayiran et al., 2017).

A tissue tonometer evaluates the tissue resistance to compression. It can be used to assess the skin pliability and fibrosis during lymphedema treatment. While tissue dielectric constant can measure skin texture and resistance, imaging techniques are able to show the presence of extra fluid within the tissues (Liu and Olszewski, 1992, Mayrovitz, 2009), however they are expensive and inefficient. A commercially available technology that use tissue dielectric constant measurements is LymphScanner by Delfin Technologies (Technologies).

Bioimpedance spectroscopy (BIS) is a non-invasive technique that was first used by nutritionists to assess body composition and has been used recently as a reliable in early-stage diagnosis technique of lymphedema since it assesses the extracellular fluid compartment before visible changes have settled (Cornish et al., 2001). BIS involves applying a small electrical current at frequencies ranging from 1-20 kHz to 1MHz through the body and measures the opposition to the flow of this current (defined as impedance). The electrical current is primarily conducted by the water containing fluids in the body; this water is contained both within the cells, intracellular water, and external to the cells, extracellular water. At low

frequencies, current passes through the extracellular fluid (ECF) space and does not penetrate the cell membrane, characterized by the theoretical resistance at zero frequency (R_0). At high frequencies, however, the current passes through both the intracellular fluid (ICF) and ECF. Using this principle, a value of impedance can be calculated. The measured impedance is inversely proportional to the amount of fluid (Erdogan Iyigun et al., 2015). An early report of the use of this technique was published in 1996 where it was shown that BIS technique is significantly more sensitive than circumferential measurements and able to detect small differences in the extracellular volumes between the extremities of a patient (Cornish et al., 2001). Recently, it has been shown that BIS predicted the onset of lymphedema 10 months before the condition could be clinically diagnosed, meaning before there were visible symptoms (Erdogan Iyigun et al., 2015).

Currently the existing commercially available products using BIS as a diagnostic tool are Lymphedema index (L-Dex) (Impedimed) and SOZO® (SOZO) by Impedimed. A prospective observational study demonstrated the impact of L-Dex® measurements where it reduced the incidence of clinical lymphedema from 36.4% to 4.4% in a clinical practice (Soran et al., 2014). However, these devices are costly and not portable. Only the most specialized rehabilitation centres have access to equipment that use BIS to obtain a more accurate monitoring of the progression of lymphedema. Performing the surveillance only at the hospital and with big intervals between the check-ups leads to late diagnosis and often lymphedema detection might be done at an irreversible stage.

4. DESCRIPTION OF THE DEVICE

Non-invasive regular patient monitoring in home environment presents a high interest in healthcare today. To follow regularly the patient's health state, a portable measurement device which is compact, low cost, low power, and capable of performing measurement with adequate accuracy is highly desirable both for hospital and home use.

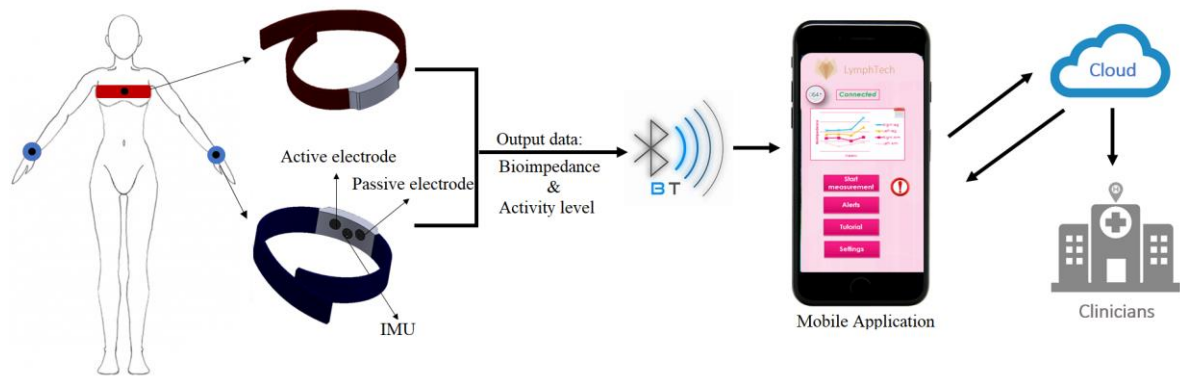

Figure 1: Detailed scheme of the operation: bioimpedance data, acquired by the wearable device, are transferred by Bluetooth to a mobile phone application. After data analysis, biofeedback is sent to the patient and the clinicians. The device includes two bracelets, a belt and a recording/controller module. Each bracelet includes an active electrode, a passive electrode and an IMU. The belt includes an active electrode and a passive electrode.

In this paper it is proposed a portable home-monitoring device for early diagnosis of lymphedema following breast cancer surgery. The device is intended to be used regularly to monitor the patient and detect in time the lymphedema.

The system, shown in Figure 1, comprises a BIS device and a mobile application. The device includes two adjustable bracelets, a belt and a recording/controller module. Each bracelet includes an active electrode for delivering AC current and a passive electrode for performing impedance measurement and an inertial measurement unit (IMU) to measure the accelerations. The belt includes an active electrode and a passive electrode.

The recording/controller module is designed to send multi-frequency signals through the limbs, to record the output and to process the signal to calculate the lymphedema risk. The whole device is meant to be portable using an internal rechargeable battery encased into the recording/controller module.

To perform the upper limbs impedance measurements, the user must wear the bracelets over the wrists and the belt over the chest as shown in Figure 2a. To perform the lower limbs impedance measurements, the user must wear the bracelets over the ankles and the belt over the hips as shown in Figure 2b.

Each limb is assessed separately by sending the AC current from the belt to the bracelet by means of active electrodes.

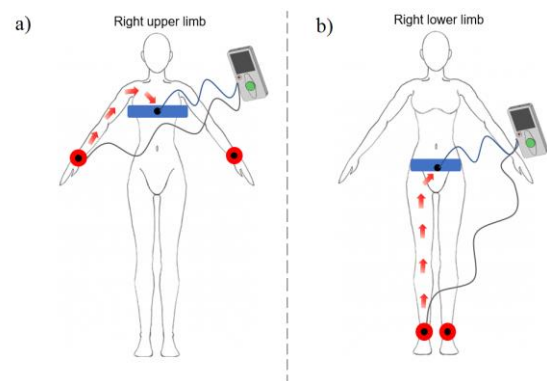

Figure 2: Electrodes' positions to perform a measurement with the device. For upper limb measurement (a), the current passes from the wrist to the chest. For lower limb measurement (b), the current passes from the ankle to the hips.

To avoid wrong measurements affected by motion artefact the bioimpedance measurements are only taken place once the level of activity measured by the IMU is low. The bioimpedance measurements are then stored to the memory card and sent via Bluetooth module to the mobile phone.

The mobile application will provide the access to the measured data, stored via Cloud, to the user. The app will send notifications to remind the user to take the measurement and alert the patient for increased risk of developing the lymphedema.

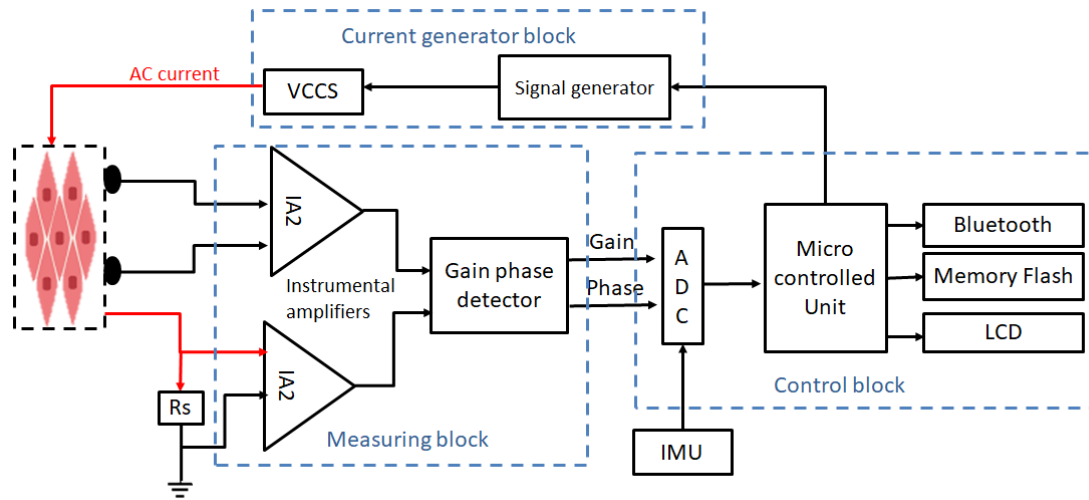

Figure 3: Schematics of the bioimpedance measurement device.

4.1 Technical requirements

The solution must: (1) provide multi-frequency currents between two points located at the extremes of the body parts of interest; (2) measure the related bioimpedance and (3) store the measurements in a flash memory and send them via Bluetooth module to the mobile phone.

In addition, to avoid high signal noise by motion or physical activity the bioimpedance measurements can only take place once the activity level measured is low. Therefore, an accelerometer sensor is included as a technical aspect to control the measurement process.

The schematic of our bioimpedance measurement device is shown in Figure 3.

As said, in bioimpedance measurement system, a small AC current passes through the body and the opposition to the flow of this current (defined as impedance) is measured. To achieve a suitable accuracy is necessary that the output current is stable and within safe magnitudes for a wide bandwidth.

For patient safety, a maximal AC-current of 0.5mA and frequency range between 1 kHz and 1MHz must be adopted.

Moreover, to keep the output current stable over the frequency range independently of load changes, the output impedance should be maintained higher than the load impedance, so that the major part of the current is given to the output and the inner losses of the source are reduced.

4.2 Hardware

The recording/controller module includes a signal (sine wave) generator, a voltage controlled current source (VCCS), two identical instrumentation amplifiers, a Gain Phase Detector (GPD), an Analogue Digital Converter (ADC) and a microcontroller unit (MCU). The battery needed for the system, is a common rechargeable of 5V.

The signal generator and the VCCS generate a sinusoidal current at pre-programmed frequencies in the range of 1 kHz to 1 MHz. The amplified voltage drops across the tissue and the reference resistor R_s , are fed into the GPD which outputs two voltages proportional to their magnitude's ratio and phase difference, respectively. The gain and the phase extracted are used to compute the impedances at each frequency and then the values are displayed on the screen, sent to Bluetooth module and stored in on-board memory by MCU.

As mentioned in the requirement section, the accuracy and conformity of the excitation current can affect the quality of the measurements and also the safety of patients. Therefore, the VCCS block plays an important role in the design.

A high-performance current source for portable bioimpedance spectrometer should have high bandwidth, high output impedance over the chosen frequency range, and stable and safe injected current lower than 0.5mA.

Different topologies of VCCS have been proposed such as current conveyors, Howland current source or Tietze current source (Bragos et

al., 1994, Tietze et al., 2014, Horowitz and Hill, 2015).

Among the available configuration, we opted for the modified version of the Howland current source proposed by P. Horowitz and W. Hill (Horowitz and Hill, 2015) and showed in Figure 4.

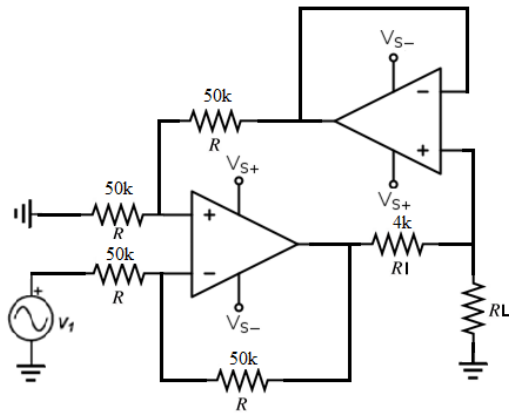

Figure 4: Modified Howland current source.

In this version of the circuit all four resistors in the positive and negative feedback lines have equal values, so the circuit works without any amplification. The load current depends only on input voltage and value of current forcing resistor R_I and is independent of the load resistance. To ensure a stable and accurate voltage controlled current source the operational amplifier should be selected carefully. In particular, amplifier with high common mode rejection ratio (CMRR), low input voltage noise and acceptable wide bandwidth are preferred.

In order to verify the operation of the selected circuit, computer simulation was performed with Cadence® Pspice® Lite 16.6. The AD8021 operational amplifier was selected for its high low input voltage noise ($2.1 \text{ nV}/\sqrt{\text{Hz}}$) and wide bandwidth (490 MHz). The current source was designed to deliver sinusoidal current of maximum amplitude $150 \mu\text{A}$ for 0.6 V of input voltage, so the R_I in this circuit is $4 \text{ k}\Omega$. Figure 5 shows the results of the output current and output impedance of the circuits in frequency domain varying the load impedance value (R_L) from 100Ω to $5 \text{ k}\Omega$.

The measuring block comprises two instrumentation amplifiers with high bandwidth and high CMRR and a gain phase detector.

The GDP was chosen because it is fast in measurement and simple in design as compared to bridge method (Steendijk et al., 1993) or the quadrature demodulation method (Pallás-Areny and Webster, 1993). It measures the gain and phase difference of two signals as voltage outputs.

AD8302 from Analog Devices is chosen as GDP. The outputs of GDP are feed into ADCs of the microcontroller system. Also, the accelerometer's signal from IMU is sent to MCU.

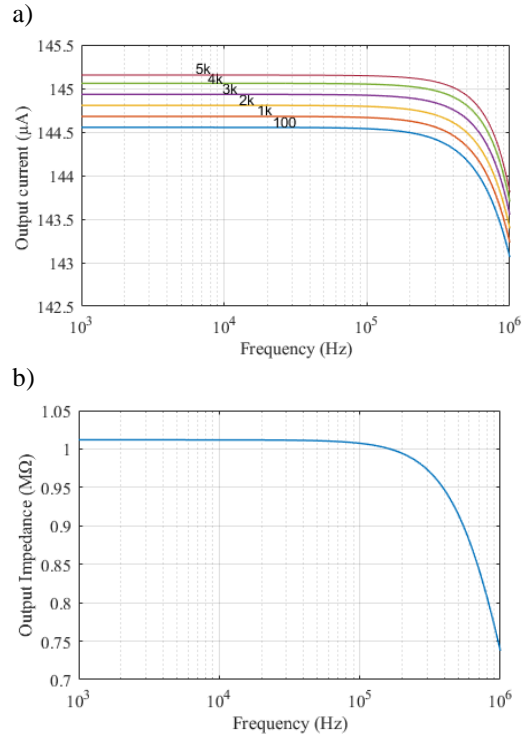

Figure 5: (a) Output current of VCCS for $R_L=100 \Omega$, $1 \text{ k}\Omega$, $2 \text{ k}\Omega$, $3 \text{ k}\Omega$, $4 \text{ k}\Omega$, $5 \text{ k}\Omega$. (b) Output impedance of VCCS.

4.3 Software

The signal processing takes place in the MCU. The microcontroller system performs different tasks with the on-board components. It interfaces with the signal generator sweeping the frequencies, calculates the impedances from the signals of the GDP, displays the results on LCD screen, stores them on a FLASH memory and sends them through Bluetooth to the smartphone, which stores the measurements in a cloud server.

Every 5 sec the total energy, which correspond to the activity level, is computed from the raw accelerometer signal. If the energy is below the fixed threshold, the MCU initiate the bioimpedance measurements.

The gain and the phase extracted from GPD are used to compute the impedance at each frequency.

The last part of analysis is done by the mobile phone since requires a higher computational cost.

The impedance data are used to predict the impedance at zero and infinite frequencies that

cannot be measured directly. As mentioned before, the impedance at zero frequency (R_0) represents the extracellular water (ECW) compartment while the impedance at infinite frequency (R_∞) represents the total tissue water. Thus, the impedance at zero frequency is a measure of the water volume, including lymph. To derive the intracellular fluid (ICF) instead the following formula is used:

$$R_w = \frac{R_0 \cdot R_\infty}{R_0 - R_\infty} \quad (1)$$

R_0 and R_∞ are computed using the Cole model (Kyle et al., 2004).

Different methods have been used to assess lymphedema with bioimpedance measures. However, none of these provides an absolute measure of lymphedema but rather a comparison of the affected limb with that of the unaffected one (Cornish et al., 2001, Erdogan Iyigun et al., 2015, Ward et al., 2011). Clearly, there are some cases in which the lymphedema presents in both limbs where this approach cannot be used.

Therefore, the approach implemented in our device is double. Instead of comparing the two limbs at the same time, a measure of the patient at the time of diagnosis, prior to surgical intervention can be stored providing a baseline for computing the ratio. This allows for the natural asymmetry that patient may have between their arms to be accounted and detect the bilateral lymphedema as well.

Alternatively, if the measure at baseline is not available, the ratio R_0/R_w can be computed. In fact, the intracellular fluid volume is not affected by lymphedema since it is an accumulation of an extracellular fluid. A previous study has shown that this ratio differs significantly (Ward et al., 2011).

Independently by the method used to calculate the ratio, the incoming measure is compared to the stored baseline to provide an alert to the user when it exceeded the threshold. As reported in other studies, the criterion indicative of lymphedema is set at the mean +3 standard deviation of the control population (Erdogan Iyigun et al., 2015, Cornish et al., 2001, Ward et al., 2011).

The smartphone application will also show the trends of the bioimpedance measurements.

4.4 Consideration about usability, risk analysis and essential requirements

The intended use of our device is to monitor the limb's volume through bioimpedance. The target

users are the population that have undergone breast cancer surgery, at risk of developing lymphedema.

The usage involves the examination of parts and battery status of the device, the placement of the sensors and the disposition into resting position. The resting position requires the patient to sit comfortably, stay awake but relaxed and to extend his/her arms on a medium-height table. Prior to the bioimpedance measurement, a 1-minute stabilization period is held on. The measurements take 10 minutes to be carried out during which the patient must stay relaxed in the resting position. As well, consistency among measurements is required.

The device we proposed is a result of a design process, where consideration about the wearability, electrodes position and easy-to-use were considered in light of unsupervised environments use.

Figure 2 represents the intended position of the electrodes since lymphedema commonly appears in the limbs. The bracelets and the belt are adjustable and made with Velcro in order to provide a general solution for fitting people of different sizes, without influencing the comfort by tightness.

To ease the system setup and improve usability, before the start of the measurements, a tutorial is shown to the user to inform about the correct use and position of the device. The interface also provides the automatically check of the correct skin contact.

The identification of hazards derives from the known and foreseeable hazards associated with the medical device in both normal and fault conditions. The hazards have been categorized into the following groups:

- *Energy hazards*: electrostatic discharge and external electromagnetic fields influence, metallic implant in region of measurement, electric implant/pacemaker, burn due to external tattoo in the evaluation area.
- *Biological/chemical hazards*: pregnancy, irritation of skin due to previous lesion, usage during coagulant/anticoagulant medication.
- *Operational hazards*: lesion due to difficulty to adapt sensors, irritation due to pressure, humidity and/or temperature, contact with liquids during normal use.
- *Information hazards*: misuse due to incomplete instruction, labelling or packaging.

The assessment of acceptability is based upon the criteria for the acceptance of the combinations of harm probability and harm severity. A semi-

quantitative risk evaluation matrix is presented in Annex Table 1 along with the definitions of occurrence probability levels of hazards and harm severity.

5. FROM CONCEPT TO THE PRODUCT

As is well known, the translation of novel ideas into a product faces many challenges. The idea must be aligned both with the clinical and market needs. It is therefore essential to establish if the product meets the unmet needs and that there is a clear path to penetrate the market.

Lymphedema is a significant problem, that affect 3-5 million of Americans and 4 million people in Europe, where three-quarters of lymphedema cases are at stage 0 and 1, that is more than ALS, Cystic Fibrosis, Multiple Sclerosis, Muscular Dystrophy, and Parkinson's Disease combined. Moreover, only in early-stage lymphedema, the conservative treatment has been shown to be effective. Thus, there is a clear clinical need.

From the economic prospective, the early intervention reduces the need for intensive rehabilitation and it costs five times less. According to the International Lymphedema Framework, the financial impact of lymphedema in Europe is about €4 billion in loss of earnings, close to 1 billion € in health and social welfare bill and about 2 billion to treat cellulitis (International Lymphedema Framework). Shih et al (Shih et al., 2009) found that the 2-year mean costs for women with lymphedema were a significant \$23,167 higher than for patients with breast cancer without lymphedema. Stout et al. (Stout et al., 2012) reported that the cost to manage early-stage lymphedema is \$636.19 vs. \$3,124.92 per patient per year in the more advanced stages, requiring intensive therapy.

This means that for the healthcare payers' point of view, less associate cost; for the patients, an increased quality of life and for the clinicians' perspective, a deeper understanding of the phenomenon and reduced time for the visits.

Options regarding funding have being explored and structured around a combination of grants, loans, investors and equity shares. Given the social impact of breast cancer and the prevention of an associated chronic condition, a crowdfunding campaign could be expected to obtain funding to a certain extent.

The development plan for the product presented in this paper can be summarized in: data acquisition, data extraction, software component. Data acquisition mainly involves the design of the hardware that will achieve a proper acquisition of the measurements, good usability and testing. Data extraction concerns the validation of optimized signal processing. Software component involves the design of easy-to-use mobile application.

The design reviews will take place throughout the product development process to evaluate the design against technical specifications, small- and large-scale manufacturing, risk assessment and usability. Throughout the development, interviews on the design of the device with professionals and patient associations will be performed from the early stages to the market launch.

An important milestone is obtaining the proof of concept that will demonstrate the effectiveness, safety and usability of the device. This involves the in vitro testing, side by side testing with other BIS devices, pilot clinical trial, usability and acceptability studies with both patient and healthcare providers.

Once a functional device has been developed the next logical step would be to obtain clinical validation, regulatory approval, IP protection and finally scalability and launch.

6. DISCUSSION

The device presented in this paper is the first medical device that permits accurate monitoring of lymphedema progression by the user.

In addition to the time needed for medical appointments, other solutions require the acquisition of expensive equipment and/or certain level of medical expertise and have to be used at the hospital. Measurement of limb volume with water displacement can be cumbersome and difficult to perform in the physician's office; circumferential measurement of limb volume using a tape is unreliable; the use of infrared perometry is limited by the fact that the equipment is not portable and requires individuals to come into a clinic. BIS, instead, is a direct measurement of extracellular fluid volume. This technique has been studied as a tool to detect early signs of subclinical lymphedema. The existing commercially products using BIS as a diagnostic tool are costly, not portable so they are available only in specialized rehabilitation centres. The capital cost of the L-Dex U400, SOZO® is £7,500 £8,000 per unit respectively and can be used

only by trained nurse or physiotherapist, as a part of routine screening.

The solution presented is easy to implement and affordable to patients

The method proposed for the measurements can be applied to every part of the human body independently of anatomical characteristics of specific individuals (e.g. body weight, size, etc.).

The risk analysis shows that any potential damage is very unlikely thus making the operation of the device safe for individual use without any surveillance or support.

Future usability and acceptability studies should be performed involving patients in order to optimize the interface between the device and the user.

All the added values of this new design make it a highly competitive solution compared to all existing alternatives.

ACKNOWLEDGEMENTS

The authors would like to thank all the organizers of the EIT Health ClinMed 2018 summer school. Without them this project would have never born.

Special thanks for all the mentors who helped us to improve and better define this work.

The authors would also like to thank the Rehabilitation service at the Hospital Santa Maria (Lisbon, Portugal) and the Pediatric Cardiology department at the Hospital Santa Marta (Lisbon, Portugal) for hosting and enables us to have a broader view of the different healthcare providers which allows us to implement all this knowledge to design a better solution. This research was supported by a Marie Curie ITN fellowship within the 7th European Community Framework Programme (Grant Number: 676338).

REFERENCES

- Bragos, R., Rosell, J. & Riu, P. 1994. A wide-band AC-coupled current source for electrical impedance tomography. *Physiol. Meas.*, 15, A91-A99.
- Brunelle, C., Skolny, M., Ferguson, C., Swaroop, M., O'toole, J. & Taghian, A. G. 2015. Establishing and sustaining a prospective screening program for breast cancer-related lymphedema at the massachusetts general hospital: lessons learned. *J Pers Med*, 5, 153-64.
- Cornish, B. H., Chapman, M., Hirst, C., Mirolo, B., Bunce, L. H., Ward, L. C. & Thomas, B. J. 2001. Early Diagnosis of Lymphedema using multiple frequency bioimpedance. *Lymphology*, 34, 2.11.
- Erdogan Iyigun, Z., Selamoglu, D., Alco, G., Pilanci, K. N., Ordu, C., Agacayak, F., Elbuken, F., Bozdogan, A., Ilgun, S., Guler Uysal, F. & Ozmen, V. 2015. Bioelectrical impedance for detecting and monitoring lymphedema in patients with breast cancer. Preliminary results of the florence nightingale breast study group. *Lymphat Res Biol*, 13, 40-5.
- Grada, A. A. & Phillips, T. J. 2017. Lymphedema: Pathophysiology and clinical manifestations. *J Am Acad Dermatol*, 77, 1009-1020.
- IMPEDIMED. A Non-Invasive, Fluid-Specific Break Through: The Lymphedema Index (L-Dex) [Online]. <https://www.impedimed.com/products/l-dex-u400/>. [Accessed 09-12-2018].
- International Lymphedema Framework. [Online] <https://www.lympho.org/>. [Accessed 18-12-2018]
- International Society Of Lymphology. 1995. Executive Committee. The Diagnosis and Treatment of Peripheral Lymphedema. *Lymphology* 28, 113-117
- Kayiran, O., De La Cruz, C., Tane, K. & Soran, A. 2017. Lymphedema: From diagnosis to treatment. *Turk J Surg*, 33, 51-57.
- Kim, M., Shin, K. H., Jung, S. Y., Lee, S., Kang, H. S., Lee, E. S., Chung, S. H., Kim, Y. J., Kim, T. H. & Cho, K. H. 2016. Identification of Prognostic Risk Factors for Transient and Persistent Lymphedema after Multimodal Treatment for Breast Cancer. *Cancer Res Treat*, 48, 1330-1337.
- Kyle, U. G., Bosaeus, I., De Lorenzo, A. D., Deurenberg, P., Elia, M., Gomez, J. M., Heitmann, B. L., Kent-Smith, L., Melchior, J. C., Pirlich, M., Scharfetter, H., Schols, A. M., Pichard, C. & Composition of the ESPEN Working Group. 2004. Bioelectrical impedance analysis--part I: review of principles and methods. *Clin Nutr*, 23, 1226-43.
- Liu, N. F. & Olszewski, W. 1992. Use of tonometry to assess lower extremity lymphedema. *Lymphology*, 25, 155-8.
- Mayrovitz, H. N. 2009. Assessing lymphedema by tissue indentation force and local tissue water. *Lymphology*, 42, 88-98.
- National Lymphedema Network. 2011. Screening and early detection of breast cancer-related lymphedema: The imperative. [Online]. http://www.lymphnet.org/pdfDocs/PP_Lymphedema_BC_Supplement.pdf. [Accessed 09-12-2018].
- Norman, S. A., Localio, A. R., Potashnik, S. L., Simoes Torpey, H. A., Kallan, M. J., Weber, A. L., Miller, L. T., Demichele, A. & Solin, L. J. 2009. Lymphedema in breast cancer survivors: incidence, degree, time course, treatment, and symptoms. *J Clin Oncol*, 27, 390-7.
- O'toole, J., Jammallo, L. S., Miller, C. L., Skolny, M. N., Specht, M. C. & Taghian, A. G. 2013. Screening for breast cancer-related lymphedema: the need for standardization. *Oncologist*, 18, 350-2.

- Pallás-Areny, R. & Webster, J. G. 1993. Bioelectric Impedance Measurements Using Synchronous Sampling. *IEEE Transactions On Biomedical Engineering*, 40, 824-829.
- Rockson, S. G. & Rivera, K. K. 2008. Estimating the population burden of lymphedema. *Ann N Y Acad Sci*, 1131, 147-54.
- Shih, Y. C., Xu, Y., Cormier, J. N., Giordano, S., Ridner, S. H., Buchholz, T. A., Perkins, G. H. & Elting, L. S. 2009. Incidence, treatment costs, and complications of lymphedema after breast cancer among women of working age: a 2-year follow-up study. *J Clin Oncol*, 27, 2007-14.
- Soran, A., Ozmen, T., Mcguire, K. P., Diego, E. J., Mcauliffe, P. F., Bonaventura, M., Ahrendt, G. M., Degore, L. & Johnson, R. 2014. The importance of detection of subclinical lymphedema for the prevention of breast cancer-related clinical lymphedema after axillary lymph node dissection; a prospective observational study. *Lymphat Res Biol*, 12, 289-94.
- SOZO. The Power of SOZO [Online]. <https://www.hellosozo.com/>. [Accessed 09-12-2018].
- Steendijk, P., Mur, G., Van Der Velde, E. T. & Baan, J. 1993. The Four-Electrode Resistivity Technique In Anisotropic Media: Theoretical Analysis and Application on Myocardial Tissue In Vivo. *IEEE Transactions On Biomedical Engineering*, 40, 1138-1148.
- Stout, N. L., Pfalzer, L. A., Springer, B., Levy, E., Mcgarvey, C. L., Danoff, J. V., Gerber, L. H. & Soballe, P. W. 2012. Breast cancer-related lymphedema: comparing direct costs of a prospective surveillance model and a traditional model of care. *Phys Ther*, 92, 152-63.
- Taghian, N. R., Miller, C. L., Jammallo, L. S., O'toole, J. & Skolny, M. N. 2014. Lymphedema following breast cancer treatment and impact on quality of life: a review. *Crit Rev Oncol Hematol*, 92, 227-34.
- Tahan, G., Johnson, R., Mager, L. & Soran, A. 2010. The role of occupational upper extremity use in breast cancer related upper extremity lymphedema. *J Cancer Surviv*, 4, 15-9.
- TECHNOLOGIES, D. LymphScanner - Regional lymphedema [Online]. http://www.delfintech.com/en/product_information/lymphscanner/. [Accessed 09-12-2018].
- Tietze, U., Schenk, C. & Gamm, E. 2014. *Electronic Circuits - Handbook for Design and Application*.
- Torres Lacomba, M., Yuste Sanchez, M. J., Zapico Goni, A., Prieto Merino, D., Mayoral Del Moral, O., Cerezo Tellez, E. & Minayo Mogollon, E. 2010. Effectiveness of early physiotherapy to prevent lymphoedema after surgery for breast cancer: randomised, single blinded, clinical trial. *BMJ*, 340, b5396.
- Ward, L. C., Dylke, E., Czerniec, S., Isenring, E. & Kilbreath, S. L. 2011. Confirmation of the reference impedance ratios used for assessment of breast cancer-related lymphedema by bioelectrical impedance spectroscopy. *Lymphat Res Biol*, 9, 47-51.

ANNEX

Table 1: Semi-quantitative risk evaluation matrix. In red, the unacceptable residual risks and not allowed usage for those risks' conditions.

	Risk	Severity	Frquency	Control measures
R1	Irritation due to pressure, temperature and/or humidity	Minor	Occasional	-
R2	External electromagnetic fields influence	Negligible	Remote	-
R3	Electrostatic discharge	Minor	Remote	Make sure the patient is not touching metal and that there is no skin-skin contact
R4	Contact with liquids during normal use	Serious	Remote	Specify avoidance of liquids near the sensors in the instructions of use
R5	Usage during coagulant/anticoagulant medication	Catastrophic	Improbable	-
R6	Lesion due to difficulty to adapt sensors	Minor	Probable	Reevaluation of the instructions and adjustable sensors
R7	Mismeasurement due to difficulty to adapt sensors	Minor	Probable	Reevaluation of the instructions and adjustable sensors
R8	Incorrect skin contact	Minor	Probable	Alert message to rearrange the sensors of the device
R9	Metalic implant in region of measurement	Serious	Probable	Useage not allowed in the region where there is a metallic implant
R10	Misusage due to incomplete instructions	Serious	Occasional	Reevaluation of the instructions of use with patient and doctors feedback
R11	Burn due to external tattoo in evaluation area	Serious	Occasional	metallic tattoos, usually older, in the region of evaluation are banned
R12	Usage during pregnancy	Catastrophic	Remote	Usage not allowed during pregnancy
R13	Patient has an electric implant/pacemaker	Catastrophic	Occasional	Usage not allowed in the presence of pacemakers